

WELLS
DENTAL, INC.

Dental Laboratory
Equipment And Supplies



MADE IN THE
USA

ANNUAL CATALOG
2019

Providing Quality Equipment
And Exceptional Services
For Over 83 Years

ORDERING & CATALOG INFORMATION

TECHNICAL ASSISTANCE

If you want information about our products or need help to install or service your equipment, please call us. One of our experienced technicians will give you courteous, professional advice.

FACTORY REPAIR SERVICE

Since 1936, Wells Dental's multifaceted factory service program has substantially saved our customers money while restoring the quality of their Wells products. For more information on Wells repair services, see the last section of this catalog.

EQUIPMENT EXCHANGE

If you cannot be without your equipment for the one or two days it takes us to repair your item our exchange service is available. We can send you a rebuilt item with the understanding that you will return your old item to us. Enclosed with the packing list on top of the box you will find a UPS prepaid RS (return service) label. Simply enclose your old equipment in the same box and affix the prepaid return label. You can give the package to any UPS driver and the package will be returned to us. The equipment exchanged will be invoiced at full retail price which serves as a deposit. Upon receipt of your old item, appropriate credit will be issued for the difference between the retail price and the exchange price. No credit will be issued for exchanges not returned within 30 days of invoice date.

PRICE & PRODUCT CHANGES

We reserve the right to change prices, impose purchase restrictions and to make product or engineering changes at any time without prior notification.

Wells Dental today, located in the heart of the California Redwoods.

WARRANTIES

Beginning at the date of purchase, Wells equipment is warranted for the indicated periods and subject to the following conditions:

Limited, 1-year prorated*

New and rebuilt Wells Handpieces
Foot Controls
Super Quick Chucks
High Speed Spindles

1 year — New Engine Unit motors

5 years — New Whisper Arms

All warranties and guarantees are void if the equipment has been oiled or subjected to tampering or abuse. Charges for services by others will not be reimbursed unless previously authorized in writing.

***Prorated**, for terms of all Wells warranties, means:

After 30 days from the date of purchase, one twelfth of the current rebuild price will be charged per month of use up to a maximum of twelve months plus shipping.

RETURN OF GOODS

No return authorization needed. Please ship unused goods in the original packaging and enclose a copy of the invoice. Refund is subject to the condition of the goods, shipping and handling charges. Special orders are not returnable.

ORDERING

Call or fax toll-free...

Hours:

Phone: 1-800-233-0521 8 AM–4:30 PM
Pacific Time

Fax: 1-800-809-7553

URL: www.wellsdental.com

Mail: Wells Dental, Inc.
PO Box 106
5860 Flynn Creek Rd.
Comptche, CA
95427-0106 USA

PAYMENT

Terms are NET 30 days from date of invoice, on approved credit. A late fee of 1.5% per month (18% annual rate) will be charged on overdue invoices.

We accept MasterCard, Visa, American Express and Discover for advance and C.O.D. orders.



SHIPPING

Items are normally shipped UPS Ground within 24 hours. Shipments are F.O.B. Comptche, CA. They become the responsibility of the customer when the carrier accepts the goods. Inspect the shipment upon arrival and report any damages or shortages directly to the carrier. Although we do our best to meet the delivery dates supplied by our representatives, they do not constitute a guarantee. For estimated delivery time to your location, please inquire when ordering. At your request, we can ship next day (not guaranteed from our location), second day or 3 day UPS delivery.



Quiet soft action, powerful and easy to maintain, Wells engine units set the standard for quality.

Put precise power at your finger tips with a Wells complete laboratory engine unit. Tough stainless steel whisper arms move effortlessly on permanently lubricated ball bearings to ensure the smoothest motion. Choose tough Pyrrthane or economical cotton drive belts to deliver the power of 115V or 230V motor to the precision handpiece. The foot control frees your hands for more important tasks.



Engine unit shown with chrome hood.

See next page for foot control information.

ENGINE UNIT SPECIFICATIONS

Collet size:	3/32"
Maximum forward speed:	24,000 RPM
Maximum reverse speed:	20,000 RPM
Electrical rating:	115 V, 60 Hz, single-phase, 1.9 Amp*
Shipping weight:	21 lbs
*Also available:	230V, 60 Hz, single-phase, 1.0 Amp

U900 Engine Unit Gray Long Arm
• Hammered gray painted hood **\$1195.00**

U903 Engine Unit Chrome Long Arm
• Chrome plated hood **NA**

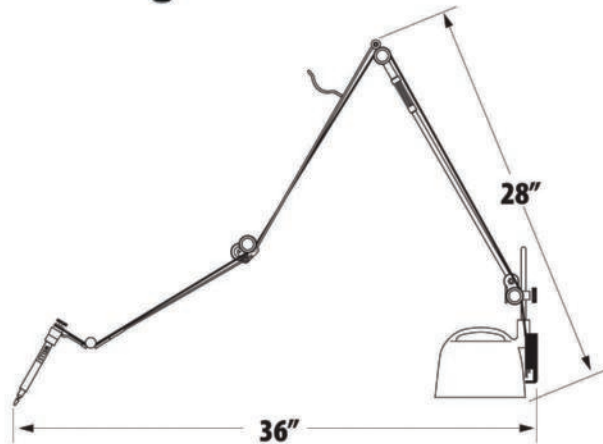

U901 Engine Unit Gray Short Arm
• Hammered gray painted hood **\$1195.00**

U904 Engine unit Chrome Short Arm
• Chrome plated hood **NA**

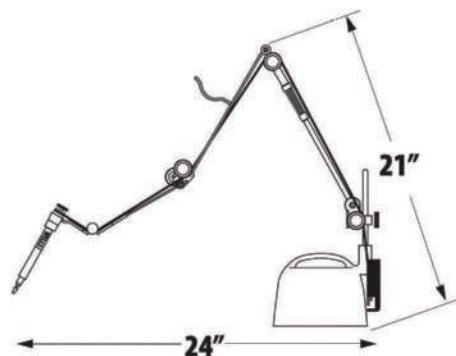

ENGINE UNITS & COMPONENTS

LABORATORY HANDPIECE & WRIST JOINT



H010	Handpiece with Wrist Joint	\$375.00
	• Permanently lubricated ball bearings	
	• Stainless steel body	
	• Precision collet	

REPLACEMENT PARTS

H108	Thumbscrew	\$16.00
H102	Collet	\$23.00
H104	Nose Cone	\$9.50
H106	Nose Cone Contra Angle	\$12.50
H110	Rubber Wrench	\$2.00
H206	Collet & Thumbscrew	\$36.00
H208	Nose Cone with Rubber Wrench	\$10.00
W011	Wrist Joint	\$138.00
W204	Spring Clip Kit	\$6.50
W102	Retaining Screw Pkg-2	\$3.50

FOOT CONTROL & REPLACEMENT PARTS



For replacement parts not listed in this catalog, please refer to your User's Manual or give us a call.

F011	Foot Control 115V	\$275.00
F013	Foot Control 230V	\$280.00

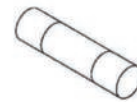

F109	Fuse 5A/250V — Pkg of 2	\$3.00
-------------	-------------------------	---------------

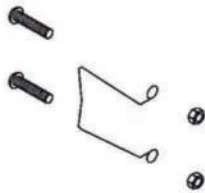

F113	Plug Retainer Kit	\$7.00
-------------	-------------------	---------------

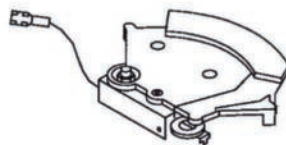

F200	Circuit Board Kit	\$135.00
-------------	-------------------	-----------------

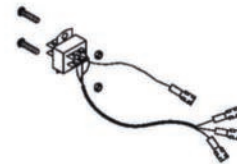

F202	Connector 6-prong male	\$19.55
-------------	------------------------	----------------



F206	Return Spring Kit	\$14.00
-------------	-------------------	----------------

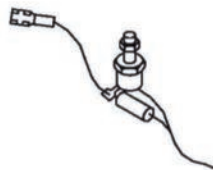

F208	Semiconductor Kit	\$36.00
-------------	-------------------	----------------

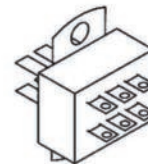

F506	Male Connector	\$9.75
-------------	----------------	---------------

ENGINE UNITS & COMPONENTS

ENGINE ARMS

- | | | |
|--------------|-------------------|----------|
| AS052 | Whisper arm long | \$350.00 |
| AS051 | Whisper arm short | \$350.00 |
- 302 stainless spring steel construction of small diameter arms and hook
 - 303 stainless steel construction of large diameter arm, post, block and pulleys
 - Permanently lubricated ball bearings



ARM PULLEYS

- | | | |
|--------------|--|---------|
| AS211 | Whisper arm pulley w/wrench | \$45.00 |
| | • Stainless steel construction | |
| | • For AS051 (short) and AS052 (long) Whisper Arms only | |
| A106 | Aluminum pulley w/wrench | \$35.00 |
| | • For A011 (Piccolo) and A012 (Standard) | |

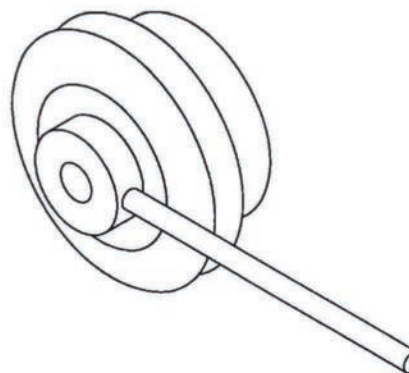

BELTS

- | | | | | | |
|--------------|---|---------|-------------|---|---------|
| AS404 | Pyrrathane belt 6' 6" | \$14.00 | A400 | Cotton belt 6' 6" — Pkg. of 2 | \$20.00 |
| | • For AS051 Whisper Arm Short and A011 Engine Arm Piccolo | | | • For AS051 Whisper Arm Short and A011 Engine Arm Piccolo | |
| AS406 | Pyrrathane belt 9' 8" | \$14.00 | A402 | Cotton belt 9' 8" — Pkg. of 2 | \$20.00 |
| | • For AS052 Whisper Arm Long and A012 Engine Arm Standard | | | • For AS052 Whisper Arm Long and A012 Engine Arm Standard | |

ENGINE UNITS & COMPONENTS

HOOD & MOTOR



Shown with hammered gray painted hood.

- E026** Hood & Motor Chrome 115V
 - 115 V, 60 Hz, Single-phase, 1.9 A motor
 - Chrome plated hood
 NA
- E027** Hood & Motor Gray 115V
 - 115 V, 60 Hz, Single-phase, 1.9 A motor
 - Hammered gray painted hood
 \$499.00
- E028** Hood & Motor Chrome 230V
 - 230 V, 60 Hz, Single-phase, 1.0 A motor
 - Chrome plated hood
 NA
- E029** Hood & Motor Gray 230V
 - 230 V, 60 Hz, Single-phase, 1.0 A motor
 - Hammered gray painted hood
 \$425.00

MOTOR, BRUSHES & REPAIR PARTS



- E 132** Motor 115V \$299.00
- E 133** Motor 230V \$299.00

- E101** Brushes Baldor Motor — Pkg. of 2
 - 1/8" x 3/16" x 5/8" (3.17mm x 4.76mm x 15.87mm)
 - For E132 Baldor Motor
 \$20.00

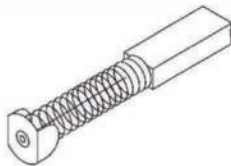

- E105** Brushes Bodine Large — Pkg. of 2
 - 1/4" x 3/8" x 1" (6.35mm x 9.53mm x 25.4mm)
 - For Large Brush E131 Motor
 \$20.00

- E107** Brushes Bodine Small — Pkg. of 2
 - 3/16" x 1/4" x 11/16" (4.76mm x 6.35mm x 17.46mm)
 - For Small Brush E129 and E130 Motor
 \$20.00

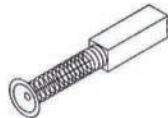

- E106** Brushes WSM Motor — Pkg. of 2
 - 1/4" x 1/4" x 3/4" (6.35mm x 6.35mm x 19.05mm)
 - For WSM motors (manufactured before Oct. 1983)
 \$20.00

- E150** Motor Pulley with Set Screw \$20.00

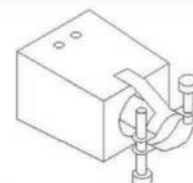
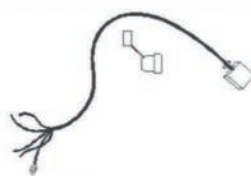

- E112** Power Cord Kit \$19.00

- E110** 5-wire Cord Kit \$39.00

- E504** Connector 6-prong Female \$8.50

For replacement parts not listed in this catalog, please refer to your User's Manual or give us a call.

Quiet operation. Fully adjustable for comfort. Jewelers taper on the left hand side.

GOLD CHROME FINISHING MACHINE

U712 Gold Chrome Machine 115V Hz 60Hz \$1409.00

- Wells High Speed Spindle Quick tool changes while lathe is running
- Wells Light Shield with tempered glass
- Wells 115 Volt, 1/3 Hp lathe
- Collet size: standard 3/32" (1/16", 1/8" or 3mm collets are available)
- Spindle RPM: 12000 (low) and 24000 (high)
- Lathe RPM: 1725 (low) and 3450 (high)
- Electrical rating: 115 Volt, 60 Hz, single phase, 3.3 Amp
- Shipping weight: 55 lbs.

Also available with 100 volt or 230 volt lathe. 50 Hz or 60 Hz

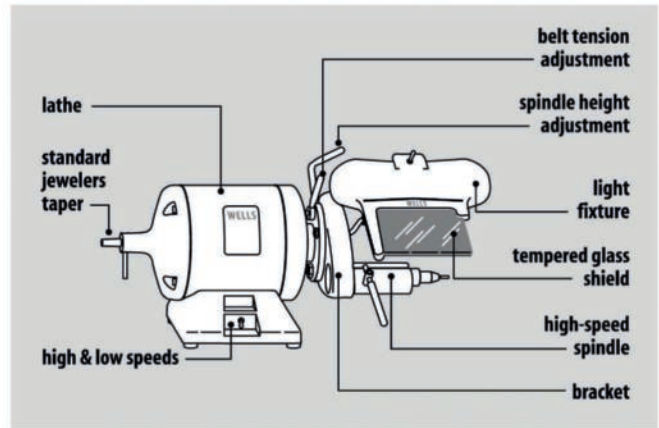
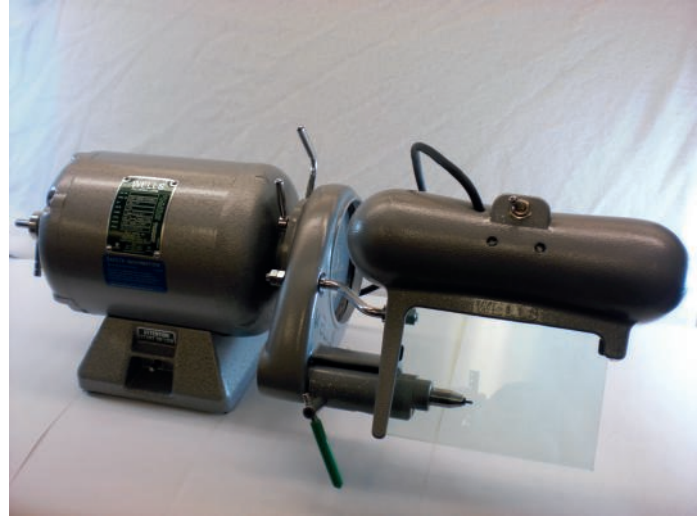

GOLD CHROME BRACKET ASSEMBLY /RW

U011 Gold Chrome Bracket Assembly/RW \$799.00

- Without lathe for field installation on a Red Wing Lathe
- Collet size: standard 3/32" (1/16", 1/8" or 3mm collets are available.)
- Shipping weight: 9lbs.



WELLS HIGH SPEED SPINDLES FOR DEMCO & TICONIUM HIGH SPEED ALLOY GRINDERS, BELT DRIVEN

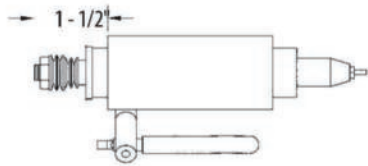

- S020** For Demco E96 High Speed Alloy Grinder \$360.00
- Standard shaft length
 - S116 with two pulley diameters for double vee belt
 - S141 Pulley Shield
 - Two 10-32 threaded mounting holes

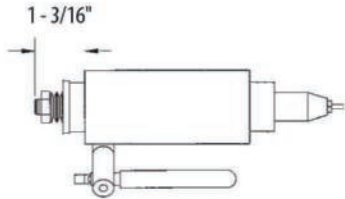

- S021** For Demco and Ticonium High Speed Alloy Grinders \$360.00
- Short Shaft
 - S118 with one pulley diameter for double vee belt
 - S141 Pulley Shield
 - Two 10-32 threaded mounting holes

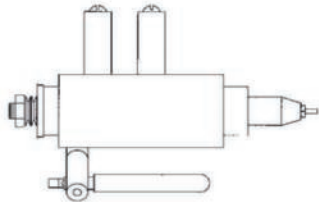

- S018** For Demco B1 High Speed Alloy Grinder \$360.00
- Short shaft
 - S118 with one pulley diameter for double vee belt
 - S141 Pulley Shield
 - S230 Smooth Mounting Tubes

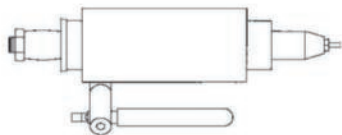

- S019** For Demco High Speed Alloy Grinder \$360.00
- S120 Pulley for flat belt
 - S141 Pulley Shield
 - Two 10-32 threaded mounting holes

WELLS HIGH SPEED SPINDLES FOR BEGO & NIRANIUM HIGH SPEED ALLOY GRINDERS

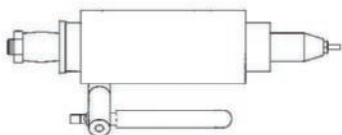

- S036** For Bego High Speed Alloy Grinder \$360.00
- S120 Pulley for flat belt
 - S141 Pulley Shield
 - Four 6mm threaded mounting holes

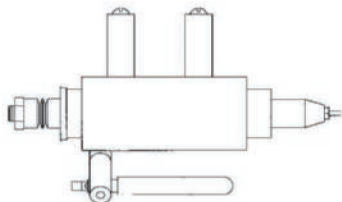

- S042** For Niranium High Speed Alloy Grinder \$360.00
- S136 Pulley for double vee belt
 - S141 Pulley shield
 - S230 Smooth Mounting Tubes

FINISHING MACHINES & COMPONENTS

HIGH SPEED SPINDLES FOR WELLS GOLD CHROME FINISHING MACHINES

- S013** For Wells Gold Finishing Machine
- S114 Pulley for double vee belt
 - Two 10-32 threaded mounting holes

\$360.00

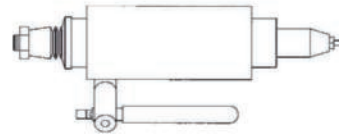

- S012** For Wells Gold Chrome "I" Finishing Machine on Red Wing Lathe
- S114 Pulley for double vee belt
 - S240 Threaded Mounting Tubes

\$360.00

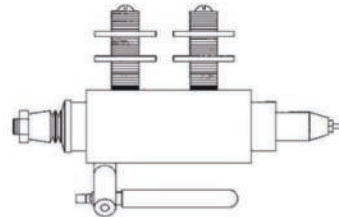

- S011** For Wells Gold Chrome "I" Finishing Machine on Red Wing Lathe
- S120 Pulley for flat belt
 - S141 Pulley Shield
 - S240 Threaded Mounting Tubes

\$360.00

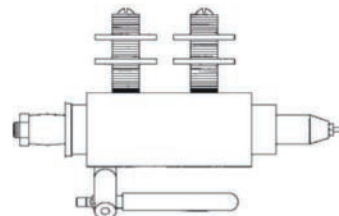

WELLS HIGH SPEED SPINDLES FOR FOSTER ALLOY GRINDERS

- S030** For Foster series III, 5A and AG04/CF Price/Whip Mix High Speed Alloy Grinder
- S134 two pulley diameters for triple vee belt
 - S519 (small) .687"-17.45mm:
 - S520 (large) 1.370"-34.80mm
 - S230 Smooth Mounting Tubes

\$360.00

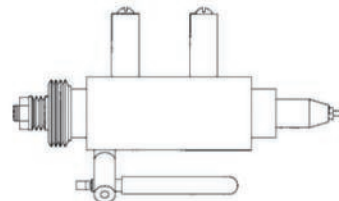

- S031** For Foster series AG03 and AG05 (variable speed)
- S135 two pulley diameters for triple vee belt
 - S521 (small) black anodized .587"-14.92mm:
 - S522 (large) black anodized 1.268"-32.20mm
 - S230 Smooth Mounting Tubes

\$360.00

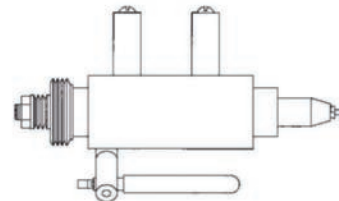

- S028** For Foster Flat Belt High Speed Alloy Grinder
- S130 and S132 two pulley diameters for flat belt
 - S141 Pulley Shield
 - S230 Smooth Mounting Tubes

\$360.00

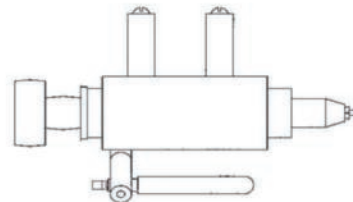

- S029** For Foster series PE3 and PEA High Speed Alloy Grinder
- S130 and S128 two pulley diameters for a flat belt
 - S141 Pulley Shield
 - Housing for clamp type mounting

\$360.00

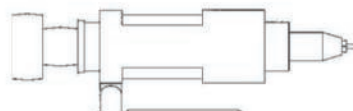

WELLS HIGH SPEED SPINDLE REPLACEMENT PARTS



Wells High Speed Spindles can be ordered to fit most alloy grinders. Please consult pages 10 & 11 for ordering information or call us for help. All spindles are shipped with S250 Accessory Kit and Users Manual.

See page 13 for mounting hardware.
See page 14 & 15 for pulleys.
See page 16 for belts.

S152	Stop Tubes set of 6	\$13.00
	Stop Tube .245 Blue	\$3.00
	Stop Tube .255 Yellow	\$3.00
	Stop Tube .265 Orange	\$3.00
	Stop Tube .275 Red	\$3.00
	Stop Tube .285 Green	\$3.00
	Stop Tube .295 Black	\$3.00
S106	Collet 3/32	\$19.50
S105	Collet 1/16	\$23.50
S108	Collet 3mm	\$21.00
S110	Collet 1/8	\$21.00
138	Shipping Rod 3/32	\$1.50
S551	Pulley Jam Nut	\$4.25
S36	Screw Set 10-32 x 3/16	\$1.00
S154	Collet Wrench 3 Jaw	\$11.00
S155	Collet Wrench 4 Jaw	\$11.00
S159	Collet Wrench 1/16	\$11.00
S161	Collet Wrench 3mm & 1/8	\$11.00
S112	Handle Kit	\$13.00
S545	Handle only no grip	\$10.00
S546	Grip 2-3/8"	\$2.00
S250	Accessory Kit	\$24.00
151	Hex Wrench 3/32	\$2.50
159	Hex Wrench 1/8	\$2.50
S152	Stop Tubes set of 6	\$13.00
S153	Stop Remove Tool	\$12.00
S165	Tube Brush 3/16	\$5.00

FINISHING MACHINES & COMPONENTS

SPINDLE MOUNTING HARDWARE FOR WELLS HIGH SPEED SPINDLES

S220

Spindle Mounting Kit

- Fastens S013 Wells High Speed Spindle to Wells Gold Chrome Finishing Machines: U011, U015, U020, U711 & U712

\$14.00

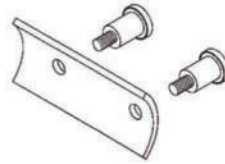

S230

Mounting Tube Smooth - Pkg of 2

- Fastens S018, S028, S030, S031 & S042 Wells High Speed Spindles to Demco B1, Foster and Niranium Grinders

\$15.00

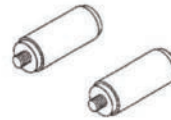

S231

Smooth Tube Rebuild Kit

\$3.00



S240

Mounting Tube Threaded - Pkg of 2

- Fastens S011 or S012 Wells high speed spindles to older Wells Gold Chrome "I" finishing machines

\$40.00

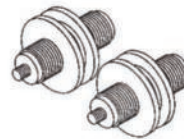

S241

Threaded Tube Rebuild Kit

\$6.50



FINISHING MACHINES & COMPONENTS

See pages 10 and 11 for pulley configurations.

SPINDLE PULLEYS FOR HIGH SPEED ALLOY GRINDING MACHINES



S141 Pulley Shield
 • For all pulleys except S114, S134 & S135

\$13.00



S128 Pulley for S029
 • Fits Foster PE3 & PEA
 • Fits older Foster Alloy Grinders with flat belt

\$10.00



S114 Pulley for S012/S013
 • Fits double v belt
 • Fits Wells Gold Chrome Finishing Machines
 • Fits Wells Gold Chrome "I" with double v belt

\$13.00



S130 Pulley for S028/S029
 • Low speed aluminum pulley
 • Fits Foster PE3 & PEA
 • Fits Foster Alloy Grinders with flat belt
 • This pulley also threads onto the spindle shaft and holds on the S128 pulley above and the S132 pulley below

\$10.00



S116 Pulley for S020
 • For double v belt
 • 2 pulley diameters
 • Fits Demo E96 (standard shaft length)

\$10.00



S132 Pulley for S028
 • Fits Foster Alloy Grinders with flat belt

\$10.00



S118 Pulley for S018/S021/S049
 • For double v belt
 • 1 pulley diameter
 • Fits Demco (short shaft), Demco B1 & Ticonium

\$13.00



S134 Pulley for S030
 • For triple v belt
 • Set of 2 pulleys;
 S519 (small) .687" - 17.45mm:
 S520 (large) 1.370" - 34.80mm
 • Fits Foster Series III & AG04 Alloy Grinders

\$13.00



S120 Pulley for S011/S019/S036
 • Fits Bego (Germany) and Demco Alloy Grinders with flat belt
 • Fits older Wells Gold Chrome "I" with flat belt

\$10.00



S135 Pulley for S031
 • For triple v belt
 • Set of 2 pulleys;
 S521 (small) black Anodized .587" - 14.92mm:
 S522 (large) black Anodized 1.268" - 32.20mm
 • Fits Foster Series AG03 and AG05 (variable speed)

\$13.00



S136 Pulley for S042/S043
 • For double v belt
 • Fits Niranium Alloy Grinders

\$10.00

FINISHING MACHINES & COMPONENTS

MOTOR PULLEYS FOR HIGH SPEED ALLOY GRINDING MACHINES



S480 Motor Pulley 2V-V/Wells
 • 4-3/8" dia, flat edged pulley for double v belt
 • For 1/2-20 threaded motor shaft
 • Fits Wells R055, R056, R057 or R058 lathe with Wells Gold Chrome Finishing Machine U712

\$38.00

S492 Motor Pulley 2V-2SP-2V/D/T
 • 2 steps 3" and 3-1/2" dia, double v pulley
 • For 1/2" dia motor shaft
 • Fits Demco, Ticonium Alloy Grinders

\$52.00



S482 Motor Pulley 2V-V/B/RW
 • 4-3/8" dia, flat edged pulley for double v belt
 • For 1/2" dia motor shaft
 • Fits Red Wing Lathe with Wells Gold Chrome Finishing Machine

\$38.00

S494 Motor Pulley Flat 2SP RS CT/F
 • 2 steps 3-7/8" dia, crowned pulley for flat belt
 • For 1/2" dia motor shaft
 • Fits Foster Alloy Grinders with flat belt

\$52.00

S484 Motor Pulley Flat Crown/RW
 • 3-7/8" dia, crowned pulley for flat belt
 • For 1/2" dia motor shaft
 • Fits Red Wing Lathe with older Wells Gold Chrome "I" with flat belt

\$52.00

S495 Motor Pulley Flat 3-1/2" Dia
 • 3-1/2" dia, crowned pulley for flat belt
 • For 1/2" dia motor shaft
 • Fits Demco Alloy Grinders with flat belt

\$52.00

S486 Motor Pulley Flat Crown/W/B
 • 3-7/8" dia, crowned pulley for flat belt
 • For 1/2" dia motor shaft
 • Fits Baldor lathe with older Wells Gold Chrome "I" with flat belt

\$52.00

S496 Motor Pulley Flat 3-3/4" Dia
 • 3-3/4" dia, crowned pulley for flat belt
 • For 1/2" dia motor shaft
 • Fits Demco Alloy Grinders with flat belt

\$52.00

S490 Motor Pulley 2V-2V/D/TIC/NIR
 • 3-1/2" dia, double v pulley
 • For 1/2" dia motor shaft
 • Fits Demco, Ticonium and Niranium Grinders

\$52.00

S498 Motor Pulley 1V2SP/Demco
 • 2 steps 3-1/8" and 3-3/8" dia, single v pulley
 • For 1/2" dia motor shaft
 • Fits Demco Alloy Grinders

\$52.00

FINISHING MACHINES & COMPONENTS

V BELTS FOR HIGH SPEED ALLOY GRINDING MACHINES

<p>S400 Belt 3M462</p> <ul style="list-style-type: none"> • Single v, 462mm (18-3/16") circumference • For Demco Low Speed Alloy Grinder 	<p>APPROX 3MM (1/8")</p>	<p>\$15.50</p>	<p>S408 Belt 2/3M487J</p> <ul style="list-style-type: none"> • Double , 487mm (19-3/16") circumference • For Demco E96 (high speed) 	<p>APPROX 6MM (1/4")</p>	<p>\$29.00</p>
<p>S402 Belt 3M475</p> <ul style="list-style-type: none"> • Single v, 475mm (18-11/16") circumference • For Demco, Baldor, Red Wing and older Wells 	<p>APPROX 3MM (1/8")</p>	<p>\$15.50</p>	<p>S410 Belt 2/3M500</p> <ul style="list-style-type: none"> • Double v, 500mm (19-11/16") circumference • For Demco 	<p>APPROX 6MM (1/4")</p>	<p>\$29.00</p>
<p>S404 Belt 3M487</p> <ul style="list-style-type: none"> • Single v, 487mm (19-3/16") circumference • For Demco special 	<p>APPROX 3MM (1/8")</p>	<p>\$15.50</p>	<p>S412 Belt 3V-21 Foster Vacuum</p> <ul style="list-style-type: none"> • Triple v, 533mm (21") circumference • For Foster Series III & AG04 Vacuum Drive 	<p>APPROX 7MM (9/32")</p>	<p>\$15.50</p>
<p>S406 Belt 2/3M475JB</p> <ul style="list-style-type: none"> • Double v, 475mm (18-11/16") circumference • For Wells Gold Chrome Finishing U712 Machine, Demco E96 (low speed), Baldor, Red Wing and Niranium 	<p>APPROX 6MM (1/4")</p>	<p>\$29.00</p>	<p>S414 Belt 3V-24 Foster Spindle</p> <ul style="list-style-type: none"> • Triple v, 610mm (24") circumference • For Foster Series III & AG04 Spindle Drive for CF Price or Whip Mix 	<p>APPROX 7MM (9/32")</p>	<p>\$15.50</p>

FLAT BELTS FOR HIGH SPEED ALLOY GRINDING MACHINES

<p>S416 Belt Flat 9/16" X 13-1/2"</p>	<p>\$26.00</p>	<p>S428 Belt Flat 9/16" X 18-3/4"</p>	<p>\$26.00</p>
<p>S418 Belt Flat 9/16" X 15"</p>	<p>\$26.00</p>	<p>S430 Belt Flat 9/16" X 19"</p>	<p>\$26.00</p>
<p>S420 Belt Flat 9/16" X 17-1/4</p> <ul style="list-style-type: none"> • For Wells with worn or recrowned pulleys 	<p>\$26.00</p>	<p>S432 Belt Flat 9/16" X 19-1/4</p> <ul style="list-style-type: none"> • For Wells with worn or recrowned pulleys 	<p>\$26.00</p>
<p>S422 Belt Flat 9/16" X 17-1/2"</p> <ul style="list-style-type: none"> • For Wells Gold Chrome "I" or Red Wing Lathe (See S420) 	<p>\$26.00</p>	<p>S434 Belt Flat 9/16" X 19-1/2"</p>	<p>\$26.00</p>
<p>S423 Belt Flat 9/16" X 18"</p>	<p>\$26.00</p>	<p>S436 Belt Flat 9/16" X 19-3/4"</p> <ul style="list-style-type: none"> • For Foster (F) with worn or recrowned pulleys 	<p>\$26.00</p>
<p>S424 Belt Flat 9/16" X 18-1/4"</p> <ul style="list-style-type: none"> • For Demco with worn or recrowned pulleys 	<p>\$26.00</p>	<p>S438 Belt Flat 9/16" X 20"</p> <ul style="list-style-type: none"> • For Foster PE3 & PEA grinder (F) (See S436) 	<p>\$26.00</p>
<p>S426 Belt Flat 9/16" X 18-1/2"</p> <ul style="list-style-type: none"> • For Demco flat belt grinder (See S424) 	<p>\$26.00</p>	<p>S440 Belt Flat 9/16" X 23"</p> <ul style="list-style-type: none"> • For Foster flat belt grinder (FB) 	<p>\$26.00</p>

To order belts

Please furnish the following:

1. Model and manufacturer of the alloy grinder
2. Serial number of the spindle
3. The type of belt (flat belt, 1, 2 or 3 v belt)
4. The circumference of the belt (total length)

To ensure correct belt size

Wrap a cord over the pulley in use and measure the length either in inches or millimeters.

SUPER QUICK CHUCKS MOUNTED ON LATHES, DIRECT DRIVEN



U510 Quick Chuck on 1/3Hp lathe 115V 60Hz \$1088.00
1725/3450 RPM
For "Heavy Duty" grinding & polishing



U523 Quick Chuck on 1/3Hp lathe with Light Shield \$1226.00
1725/3450 RPM
For "Heavy Duty" grinding & polishing

R057 Wells 1/3Hp Lathe 115V 60Hz \$760.00
1725/3450 RPM
Ready to accept Quick Chuck Q015
Clutch is Installed
For "Heavy Duty" grinding & polishing



U610 Quick Chuck on right & left side on \$1501.00
1/3 hp lathe, 115V 60 Hz
1725/3450 RPM
For "Heavy Duty" grinding & polishing



U629 Semi-Perm on right & left side on \$1319.00
1/3 hp lathe, 115V 60 Hz
1725/3450 RPM
For "Heavy Duty" polishing

SUPER QUICK CHUCK SPECIFICATIONS

Collet Sizes:	integrated 1/4" and 3/32"	
Operating speeds:	1725 and 3450 RPM	
Unit dimensions:	U510	approx. 8" X 9" X 18"
	U523	approx. 8" X 11" X 24"
Shipping weight::	U510	50 lbs
	U523	52 lbs
Shaft height::	5 1/4"	

Other Lathes & Quick Chuck combinations are available. Please call for more information

SUPER QUICK CHUCKS

If your lathe has never had a quick chuck installed, an adaptor kit is necessary. See pages 23 & 24 for adaptors.



Q015 Super Quick Chuck Right Hand \$360.00
• Shipped with Q203 accessory kit & users manual



Q011 Super Quick Chuck Left Hand \$360.00
• Shipped with Q200 accessory kit & users manual



Q023 Quick Chuck Semi-Permanent Mounted Spiral RH \$307.00



Q019 Quick Chuck Semi-Permanent Mounted Spiral LH \$307.00

SUPER QUICK CHUCK PIN SETTER

Wells Quick Pin Setter is used in conjunction with Wells Super Quick Chuck to drill precise perpendicular pin holes in plaster models. The Quick Pin Setter drills and countersinks in one easy motion. Available in grey or white.



PS02 Quick pin setter for Wells Quick Chuck, white NA



PS01 Quick pin setter for Wells Quick Chuck, grey NA
PS106 Replacement Step Drill 1/8 \$20.00

WELLS SUPER QUICK CHUCK REPLACEMENT PARTS & TOOLS

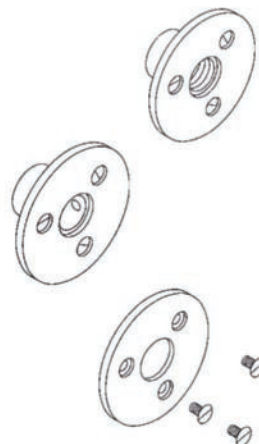
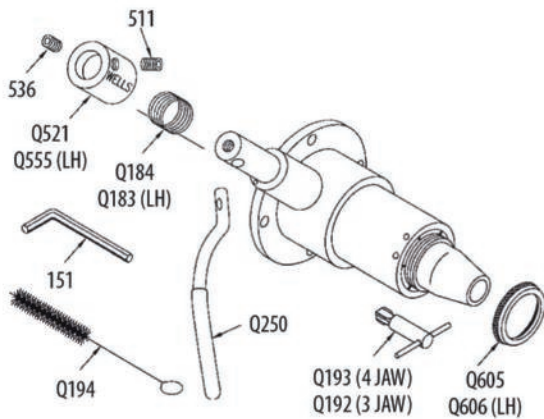
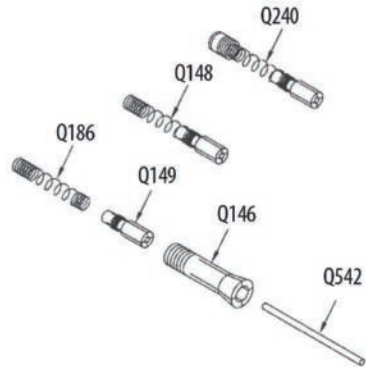
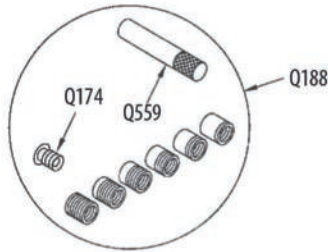

Q188	Stops - set of 6 • With stop lock screw & test rod	\$16.00
Q174	Stop Lock Screws – Pkg. of 2	\$2.75
Q559	Test Rod 1/4" • For fitting a stop to adjust the collet diameter	\$3.25
Q240	Special Collet Complete	\$25.00
Q148	Special Collet With Spring	\$24.00
Q186	Pop-Out Spring – Pkg. of 2	\$5.00
Q149	Special Collet	\$21.00
Q146	Master Collet	\$24.00
Q542	Shipping Rod 3/32" X 2-1/8"	\$1.15
511	Screw set 10-32" x 1/4"	\$1.00
536	Screw Set 10-32" X 3/16"	\$1.00
Q521	Number Cap RH	\$20.00
Q555	Number Cap LH	\$20.00
Q184	Clutch Spring RH	\$12.00
Q183	Clutch Spring LH (<i>painted red</i>)	\$12.00
Q250	Handle with Set Screw	\$13.00
Q605	Dust Cover RH	\$14.00
Q606	Dust Cover LH	\$16.00
151	Hex Wrench 3/32"	\$2.50
Q194	Tube Brush 3/8"	\$5.00
Q193	Collet Wrench 4 Jaw	\$12.00
Q192	Collet Wrench 3 Jaw	\$12.00
Q243	Clutch Wells Threaded Complete • For Quick Chuck on Wells R057 Lathe • Clutch threads onto shaft of lathe	\$37.00
Q246	Clutch Baldor/Red Wing Complete • For Quick Chuck on Baldor or Red Wing • Clutch held on with set screw	\$37.00
Q150	Clutch Lining with Screws • For all Wells Super Quick Chucks	\$20.00

SUPER QUICK CHUCK ACCESSORIES

- Q203** Accessory Kit RH \$76.00
- For Q015 Quick Chuck Right Hand
 - Q134 Spiral Chuck RH (1 included in kit)
 - Q126 Arbor Band Chuck 3/4 RH (1)
 - Q154 Mandrel with 1-64 screw RH (2)
 - Q142 Stone Chuck Tooth & Knife RH (2)
 - Q188 Stops - set of 6 (includes Stop Lock Screw and Test Rod)
 - Q194 Tube Brush 3/8
 - Q193 Collet Wrench 4 jaw
 - 151 Hex Wrench 3/32
 - Q169 Installation Screws — Pkg. of 4

See the following illustrations for details of individual accessories.

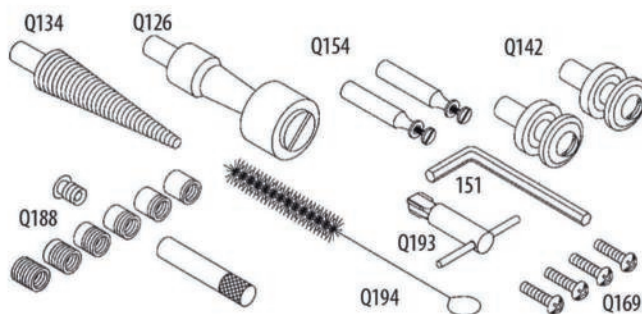

- Q200** Accessory Kit LH \$85.00
- For Q011 Quick chuck Left Hand
 - Q132 Spiral Chuck LH (1 included in kit)
 - Q124 Arbor Band Chuck 3/4 LH (1)
 - Q152 Mandrel with 1-64 screw LH (2)
 - Q140 Stone Chuck Tooth & Knife LH (2)
 - Q188 Stops - set of 6 (includes Stop Lock Screw and Test Rod)
 - Q194 Tube Brush 3/8
 - Q193 Collet Wrench 4 jaw
 - 151 Hex Wrench 3/32
 - Q169 Installation Screws — Pkg. of 4

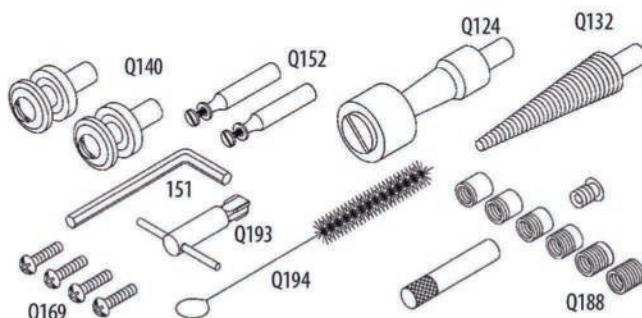

- L013** Light Shield - Quick Chuck RH \$138.00
- Light fixture and tempered glass shield
 - Installs with **right hand** Quick Chuck
 - Light bulbs are not included

- L014** Light Shield - Quick Chuck LH \$150.00
- Light Fixture and tempered glass shield
 - Installs with **left hand** Quick Chuck
 - Light bulbs are not included

- L110** Glass Shield for Wells \$19.25
- Tempered glass for L011, L013 & L014
 - 4" X 6"

- Q104** Collet Shield RH \$16.00
- Fits **right hand** Quick Chuck with knurled stainless steel dust cover (ring) only.

- Q103** Collet Shield LH \$23.50
- Fits **left hand** Quick Chuck with knurled stainless steel dust cover (ring) only.

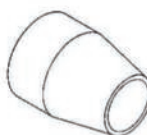
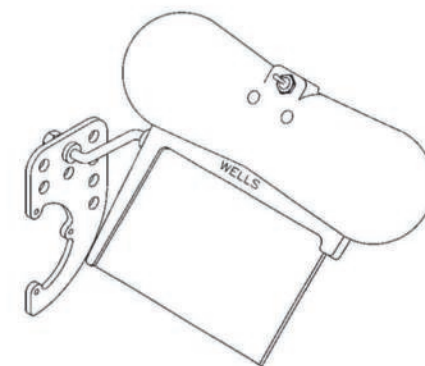

New

This non-rotating collet shield covers the collet body to provide a steady rest for more comfortable operation of your Wells Super Quick Chuck. It also helps protect rubber gloves.

SUPER QUICK CHUCK ACCESSORIES

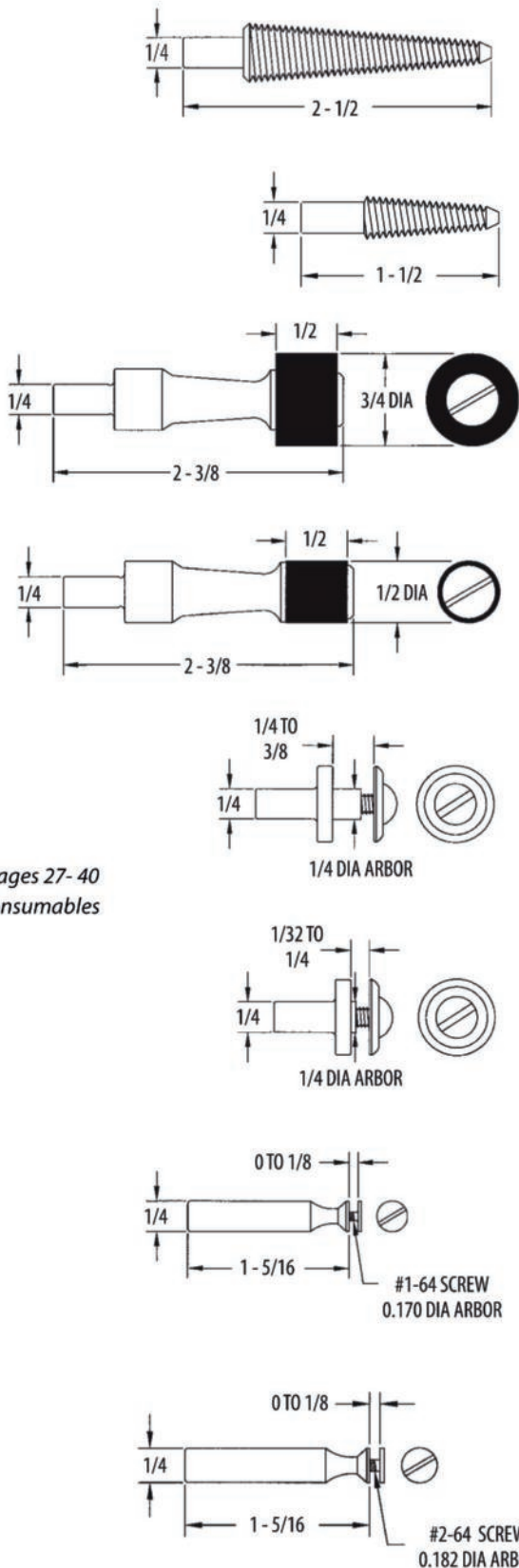

See pages 27- 40
for consumables

- | | | |
|-------------|--|---------|
| Q134 | Spiral Chuck RH
• For brushes and buffs | \$13.00 |
| Q132 | Spiral Chuck LH
• For use on the left side of the lathe | \$13.00 |
| Q131 | Spiral Chuck Short RH
• For brushes and buffs | \$13.00 |
| Q133 | Spiral Chuck Short LH
• For use on the left side of the lathe | \$13.00 |
| Q126 | Arbor Band Chuck 3/4 RH
• Expanding drum for 3/4" dia. abrasive bands | \$13.00 |
| Q124 | Arbor Band Chuck 3/4 LH
• For use on the left side of the lathe | \$13.00 |
| Q122 | Arbor Band Chuck 1/2 RH
• Expanding drum for 1/2" dia. abrasive bands | \$13.00 |
| Q120 | Arbor Band Chuck 1/2 LH
• For use on the left side of the lathe | \$13.00 |
| Q142 | Stone Chuck Tooth & Knife RH
• For wheels and stones 1/4" to 3/8" thick
• 1/4" dia. arbor | \$13.00 |
| Q140 | Stone Chuck Tooth & Knife LH
• For use on the left side of the lathe | \$13.00 |
| Q138 | Stone Chuck Thin Econo RH
• For Econo Cutters, wheels and stones
from 1/32" to 1/4" thick
• 1/4" dia. arbor | \$13.00 |
| Q136 | Stone Chuck Thin Econo LH
• For use on the left side of the lathe | \$13.00 |
| Q154 | Mandrel with 1-64 screw RH
• For separating & finishing discs
• For diamond discs & heatless wheels
• 0.170" dia. arbor | \$13.00 |
| Q152 | Mandrel with 1-64 screw LH
• For use on the left side of the lathe | \$13.00 |
| Q158 | Mandrel with 2-64 screw RH
• For separating & finishing discs
• For diamond discs & heatless wheels
• 0.182" dia. arbor | \$13.00 |
| Q156 | Mandrel with 2-64 screw LH
• For use on the left side of the lathe. | \$13.00 |

SUPER QUICK CHUCK ACCESSORIES

Q106 Burr Adapter 1/16
 • For holding 1/16" dia. shank in 1/4" chuck

\$13.50

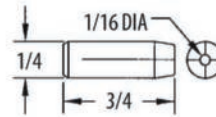

Q108 Burr Adapter 3/32
 • For holding 3/32" dia. shank in 1/4" chuck

\$13.50

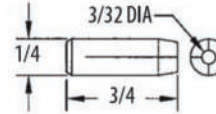

Q110 Burr Adapter 1/8
 • For holding 1/8" dia. shank in 1/4" chuck

\$13.50

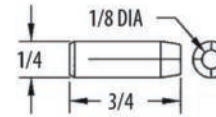

Q112 Burr Adapter 3MM
 • For holding 3mm dia. shank in 1/4" chuck

\$13.50

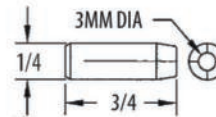

Q130 Sandpaper Chuck
 Slotted mandrel for holding sandpaper roll
 • Roll is held in place with waxed string

\$13.00

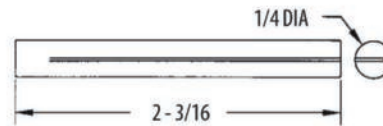

Q128 Field Sandpaper Chuck RH
 • For "Field" abrasive spiral rolls

\$13.00

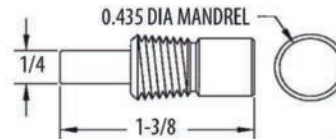

Q127 Field Sandpaper Chuck LH
 • For use on the left side of the lathe

\$13.00

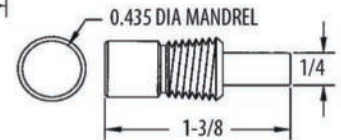

Q198 Field Sandpaper Chuck Long RH
 • For "Field" abrasive spiral rolls

\$13.00

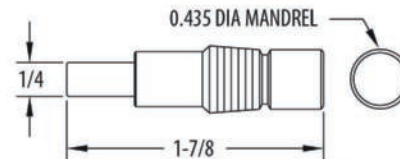

Q197 Field Sandpaper Chuck Long LH
 • For use on the left side of the lathe

\$13.00

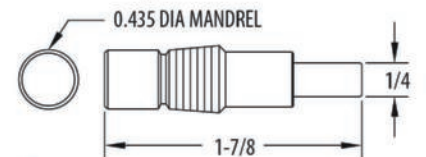

Q118 Arbor - Yates Burr
 • For "Yates" high speed steel burrs.

\$13.00

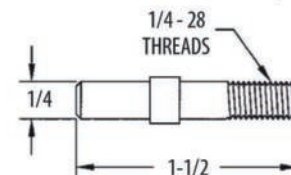

Replacement parts for these accessories are available. See the Quick Chuck User's Manual for part numbers or call us for assistance.

POLISHING LATHES

R051



R051 (Shown) **\$615.00**

Baldor 380T Lathe 1/3 Hp

- "Heavy Duty" laboratory polishing lathe
- Two Speeds, 1725 and 3450 rpm
- 1/3 Hp, 115 Volt, 60 Hz, 1 phase motor
- Standard Jeweler's taper (1/4" per ft.) with chuck ejector on both ends

*The 1/3 hp lathe is also available in 100 or 230 volts
Shipped from manufacturer NON-RETURNABLE*

R054 (Not Shown) **\$529.00**

Baldor 340 Lathe 1/4 Hp

- "Light Duty" laboratory polishing lathe
- Two Speeds, 1800 and 3600 rpm
- 1/4 Hp, 115 Volt, 60 Hz, 1 phase motor
- Standard Jeweler's taper (1/4" per ft.) with chuck ejector on both ends

Shipped from manufacturer NON-RETURNABLE

LATHE ACCESSORIES

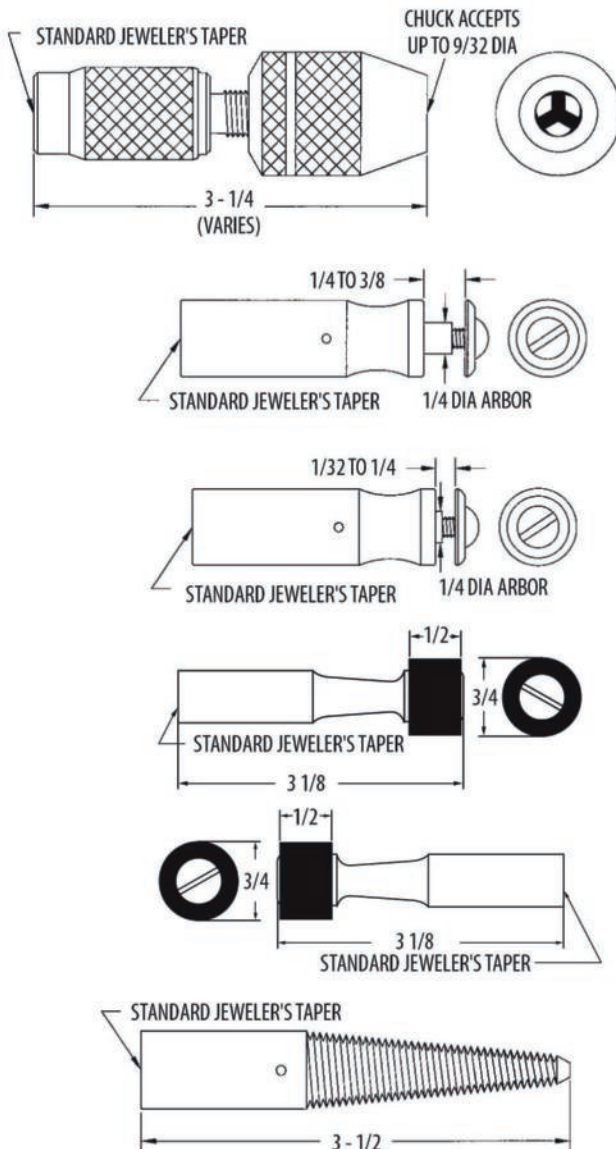

See pages 23-36 for consumables

R131 3 Jaw Chuck RH **\$57.00**

- For tools with up to 9/32" (7mm) shank
- For use on the right side of the lathe

R130 3 Jaw Chuck LH **\$57.00**

- For tools with up to 9/32" (7mm) shank
- For use on the left side of the lathe

R133 Stone Chuck Taper Shaft RH **\$14.00**

- For wheels and stones 1/4" to 3/8" thick
- 1/4" dia. arbor

R132 Stone Chuck Taper Shaft LH **\$14.00**

- For use on the left side of the lathe

R135 Thin Econo Taper Shaft RH **\$14.00**

- For Econo Cutters, wheels and stones from 1/32" to 1/4" thick
- 1/4" dia. arbor

R134 Thin Econo Taper Shaft LH **\$14.00**

- For use on the left side of the lathe

R148 Arbor Band Taper Shaft 3/4 RH **\$14.00**

- Expanding drum for 3/4 dia. abrasive bands

R147 Arbor Band Taper Shaft 3/4 LH **\$14.00**

- For use on the left side of the lathe

R137 Spiral Taper Shaft RH Stainless Steel **\$14.00**

- For brushes and buffs

R136 Spiral Taper Shaft LH Stainless Steel **\$14.00**

- For use on the left side of the lathe.

R139 Spiral Brass Taper Shaft RH **\$16.00**

- Solid brass for brushes and buffs

R138 Spiral Brass Taper Shaft LH **\$16.00**

- For use on the left side of the lathe

SUPER QUICK CHUCK ADAPTORS

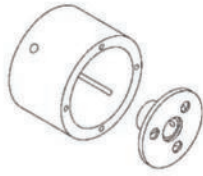

- Q206** Adapter Red Wing \$70.00
 • Fits all Red Wing Lathes

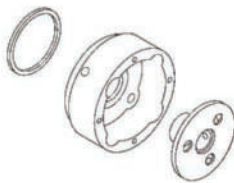

- Q212** Adapter Baldor 210/211/221/240 \$70.00
 • Fits Baldor 210 and 211 Lathes with 35mm or 40mm bearing.
 • Fits Baldor 221 and 240 Lathes with 35mm or 40mm bearing.
 • Q508 adapter ring 40mm is included for lathes with 40mm bearings.
 Note: Fits lathes with removable chuck ejector assembly (see figure A).

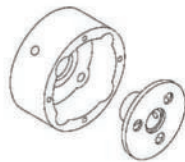

- Q218** Adapter Baldor 300 Series \$70.00
 • Fits Baldor 350, 353, 357, 359, 370, 380, and 350T & 353T if it has the end plate illustrated in Figure A with a removable chuck ejector assembly

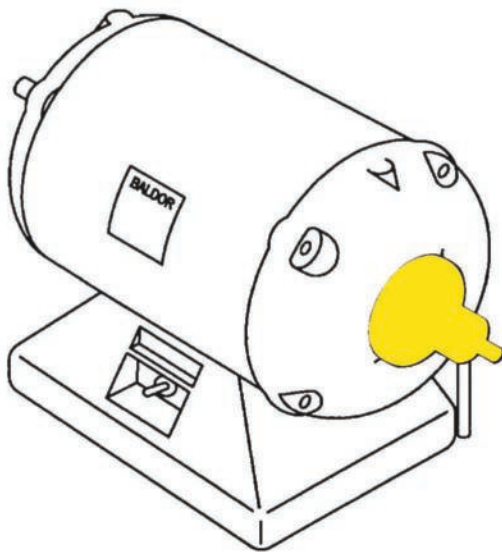

FIGURE A

Lathe Condition:

The lathe should be in good running condition. If it has noisy bearings, a worn switch, starting problems or excessive end play (greater than 1/32"), the condition should be corrected before proceeding with the installation. The condition of the tapered shaft is not important because it is not used.

SUPER QUICK CHUCK ADAPTORS

Q223 Adapter Robbins & Myers
 • Fits Robbins and Myers Lathe

\$103.00

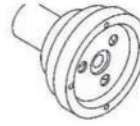

Q226 Adapter Ritter A
 • Fits Ritter model A

\$103.00



Q229 Adapter Ritter C
 • Fits Ritter model C

\$103.00

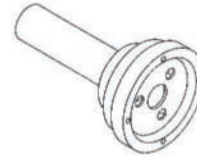

Q237 Adapter Baldor end plate
 • Fits Baldor 357T, 359T, 380T, Wells R051, R052, R053 and Baldor 350T & 353T if it has the end plate illustrated in Figure B where the chuck ejector screws directly into the end plate.

\$130.00

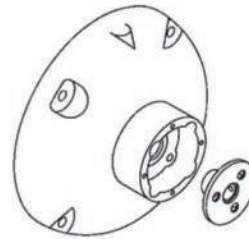

Q239 Adapter Baldor 340 end plate
 • Fits Baldor 340 only

\$130.00

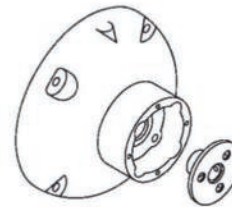

To Order Adapter

Please have the lathe manufacturer's name, model number, catalog number, serial number and spec. number from the lathe name plate to help determine the correct adapter.

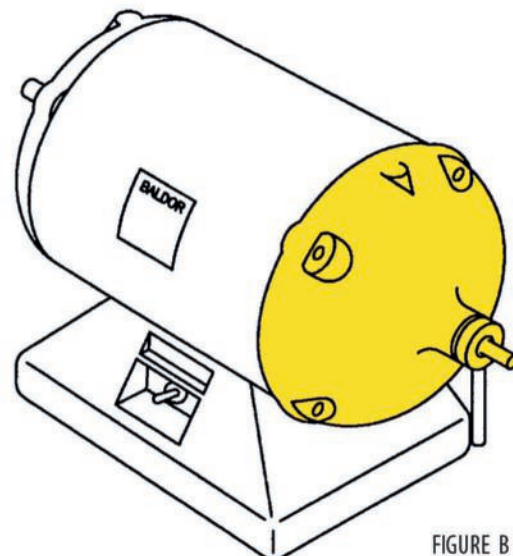
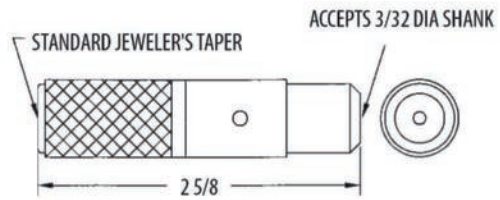

FIGURE B

LATHE ACCESSORIES

- P011** Precision Chuck 3/8" taper \$88.00
- Quick change burr chuck
 - For tools with 3/32" dia shank
 - Tools may be changed while lathe is running
 - Fits standard jeweler's taper shaft



- P012** Precision Chuck 1/4 Shaft \$88.00
- Quick change burr chuck
 - For tools with 3/32" dia shank
 - Tools may be changed while lathe is running
 - Fits any chuck that accepts a 1/4" dia. shaft

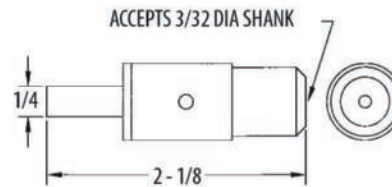

- R142** Shaft Guard RH /Wells/B \$25.00
- Fits Wells and Baldor polishing lathes
 - Covers the shaft on the right side of the lathe
 - Identified by one groove on its exterior

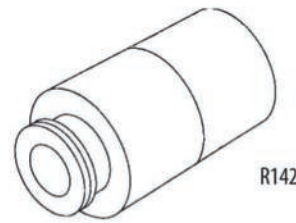

- R141** Shaft Guard LH/Wells/B \$25.00
- Fits Wells and Baldor polishing lathes
 - Covers the shaft on the left side of the lathe
 - Identified by three grooves on its exterior

- R144** Shaft Guard RH/RW#2 \$25.00
- Fits Red Wing lathe with one piece chuck remover
 - Covers the shaft on the right side of the lathe
 - Shaft guard is male threaded
 - Identified by two grooves on its exterior

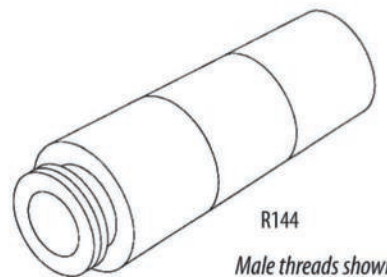

- R143** Shaft Guard LH/RW#2 \$25.00
- Fits Red Wing lathe with one piece chuck remover
 - Covers the shaft on the left side of the lathe
 - Shaft guard is male threaded
 - Identified by five grooves on its exterior

- R146** Shaft Guard RH/RW#1 \$25.00
- Fits Red Wing lathe with two piece chuck remover
 - Covers the shaft on the right side of the lathe
 - Shaft guard is female threaded
 - Identified by two grooves on its exterior

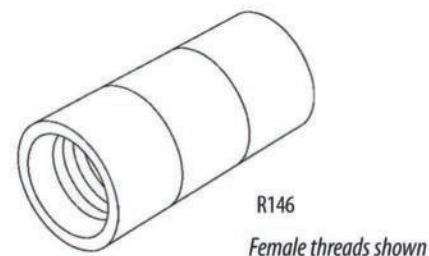

- R145** Shaft Guard LH/RW#1 \$25.00
- Fits Red Wing lathe with two piece chuck remover
 - Covers the shaft on the left side of the lathe.
 - Shaft guard is female threaded
 - Identified by three grooves on its exterior

The Shaft Guard satisfies OSHA regulations for covering rotating shafts.

BURRS

Our principle is to provide the optimum solution in terms of quality and cost. One of our solutions is the TN-Titanium Nitride coated carbide burr. These TN coated carbide burrs last at least three times long as uncoated burrs before resharpening. All our carbide burrs are available with TN Coating.



		UNCOATED	COATED
UC-SA-61-A	Burr (diamond cut)	\$16.00	
TN-SA-61-A	Burr (diamond cut)		\$18.00
UC-SF-61	Burr (diamond cut)	\$16.00	
TN-SF-61	Burr (diamond cut)		\$18.00
UC-SA-61	Burr (diamond cut)	\$16.00	
TN-SA-61	Burr (diamond cut)		\$18.00
UC-SG-61	Burr (diamond cut)	\$16.00	
TN-SG-61	Burr (diamond cut)		\$18.00
UC-SC-61	Burr (diamond cut)	\$16.00	
TN-SC-61	Burr (diamond cut)		\$18.00
UC-SM-61	Burr (diamond cut)	\$16.00	
TN-SM-61	Burr (diamond cut)		\$18.00
UC-SN-61	Burr (diamond cut)	\$16.00	
TN-SN-61	Burr (diamond cut)		\$18.00
UC-SD-61	Burr (diamond cut)	\$16.00	
TN-SD-61	Burr (diamond cut)		\$18.00
UC-SE-61	Burr (diamond cut)	\$16.00	
TN-SE-61	Burr (diamond cut)		\$18.00
UC-53D	Burr (regular cut 3/16" Ball)	NA	
TN-53D	Burr (regular cut 3/16" Ball)		\$23.00
UC-51A	Burr (regular cut)	\$19.00	
TN-51A	Burr (regular cut)		\$23.00
UC-61-81A	Burr (regular cut)	\$19.00	
TN-61-81A	Burr (regular cut)		\$23.00
UC-73C	Burr (regular cut)	\$19.00	
TN-73C	Burr (regular cut)		\$23.00
UC-88A	Burr (regular cut)	\$19.00	
TN-88A	Burr (regular cut)		\$23.00
UC-83E	Burr (regular cut)	\$19.00	
TN-83E	Burr (regular cut)		\$23.00

CONSUMABLES

BURRS

Lasts THREE times longer.

		UNCOATED	COATED
UC-84-T	Burr (regular cut)	NA	
TN-84-T	Burr (regular cut)		\$23.00
UC-84-T/LH	Burr (regular cut, left hand)	\$24.00	
TN-84-T/LH	Burr (regular cut, left hand)		\$28.00
UC-84-T/XC	Burr (extra coarse cut)	NA	
TN-84-T/XC	Burr (extra coarse cut)		\$23.00
UC-84-T/XF	Burr (extra fine cut)	NA	
TN-84-T/XF	Burr (extra fine cut)		\$23.00
UC-82-T	Burr (regular cut)	\$19.00	
TN-82-T	Burr (regular cut)		\$23.00
UC-82-T/XC	Burr (extra coarse cut)	\$19.00	
TN-82-T/XC	Burr (extra coarse cut)		\$23.00
UC-82-T/XF	Burr (extra fine cut)	\$19.00	
TN-82-T/XF	Burr (extra fine cut)		\$23.00
UC-63-B	Burr (regular cut)	\$19.00	
TN-63-B	Burr (regular cut)		\$23.00
UC-63-B/XC	Burr (extra coarse cut)	\$19.00	
TN-63-B/XC	Burr (extra coarse cut)		\$23.00
UC-63-B/XF	Burr (extra fine cut)	\$19.00	
TN-63-B/XF	Burr (extra fine cut)		\$23.00
UC-53-A	Burr (regular cut)	NA	
TN-53-A	Burr (regular cut)		\$23.00
UC-53-A/XC	Burr (extra coarse cut)	\$19.00	
TN-53-A/XC	Burr (extra coarse cut)		\$23.00
UC-53-A/XF	Burr (extra fine cut)	\$19.00	
TN-53-A/XF	Burr (extra fine cut)		\$23.00
UC-52-D	Burr (regular cut, 1/4" Ball)	NA	
TN-52-D	Burr (regular cut, 1/4" Ball)		\$23.00
UC-52-D/XC	Burr (extra coarse cut, 1/4" Ball)	NA	
TN-52-D/XC	Burr (extra coarse cut, 1/4" Ball)		\$23.00
UC-52-D/XF	Burr (extra fine cut, 1/4" Ball)	\$19.00	
TN-52-D/XF	Burr (extra fine cut, 1/4" Ball)		\$23.00
UC-52-C	Burr (regular cut)	\$19.00	
TN-52-C	Burr (regular cut)		\$23.00
UC-52-C/XC	Burr (extra coarse cut)	\$19.00	
TN-52-C/XC	Burr (extra coarse cut)		\$23.00
UC-52-C/XF	Burr (extra fine cut)	\$19.00	
TN-52-C/XF	Burr (extra fine cut)		\$23.00
UC-47-XF	Burr (extra fine cut)	\$19.00	
TN-47-XF	Burr (extra fine cut)		\$23.00
UC-47-XC	Burr (extra coarse cut)	\$19.00	
TN-47-XC	Burr (extra coarse cut)		\$23.00



Lasts **THREE** times longer.

BURRS



UC-41P UC-44C UC-31P UC-32P UC-33C UC-71G
TN-41P TN-44C TN-31P TN-32P TN-33C TN-71G

TOP VIEW



UC-88-A-4 UC-88-C-4 UC-88-T-4
TN-88-A-4 TN-88-C-4 TN-88-T-4
UC-88-B-4 TN-88-B-4



UC-A3/8 TN-A3/8
UC-A3/8 LH TN-A3/8 LH left hand
UC-B3/8 TN-B3/8
UC-B3/8 DIA TN-B3/8 DIA
UC-C3/8 TN-C3/8
UC-D3/8 TN-D3/8
UC-D3/8 LH TN-D3/8 LH left hand
UC-E3/8 TN-E3/8
UC-F3/8 TN-F3/8

Diamond Cut

	UNCOATED	COATED
UC-41P	\$16.00	
TN-41P		\$18.00
UC-44C	\$16.00	
TN-44C		\$18.00
UC-31P	NA	
TN-31P		\$18.00
UC-32P	\$16.00	
TN-32P		\$18.00
UC-33C	\$16.00	
TN-33C		\$18.00
UC-71G	\$16.00	
TN-71G		\$16.00
UC-88-A-4	\$18.00	
TN-88-A-4		\$24.00
UC-88-B-4	\$18.00	
TN-88-B-4		\$24.00
UC-88-C-4	\$18.00	
TN-88-C-4		\$24.00
UC-88-T-4	NA	
TN-88-T-4		\$24.00
UC-A3/8	NA	
TN-A3/8		\$46.00
UC-A3/8 LH	NA	
TN-A3/8 LH		\$53.50
UC-B3/8	\$38.00	
TN-B3/8		\$46.00
UC-B3/8 DIA	\$38.00	
TN-B3/8 DIA		\$46.00
UC-C3/8	\$38.00	
TN-C3/8		\$46.00
UC-D3/8	\$38.00	
TN-D3/8		\$46.00
UC-D3/8 LH	\$45.50	
TN-D3/8 LH		\$53.50
UC-E3/8	\$38.00	
TN-E3/8		\$46.00
UC-F3/8	\$38.00	
TN-F3/8		\$46.00

CONSUMABLES

BURRS

For gross removal of plaster

		UNCOATED	COATED
UC-84-T/SP	Burr (alum cut)	\$26.00	
TN-84-T/SP	Burr (alum cut)		\$30.00
UC-88-A/SP	Burr (alum cut)	\$26.00	
TN-88-A/SP	Burr (alum cut)		\$30.00
UC-A3/8 SP	Burr (alum cut)	\$45.00	
TN-A3/8 SP	Burr (alum cut)		\$53.00
UC-A1/2 SP	Burr (alum cut)	\$57.00	
TN-A1/2 SP	Burr (alum cut)		\$68.00
UC-A1/2	Burr (regular cut)	\$48.00	
TN-A1/2	Burr (regular cut)		\$58.00
UC-A1/2 LH	Burr (regular cut, left hand)	NA	
TN-A1/2 LH	Burr (regular cut, left hand)		\$68.00
UC-B1/2	Burr (regular cut)	\$48.00	
TN-B1/2	Burr (regular cut)		\$58.00
UC-B1/2DIA	Burr (diamond cut)	\$50.00	
TN-B1/2DIA	Burr (diamond cut)		\$61.00
UC-C1/2	Burr (regular cut)	\$48.00	
TN-C1/2	Burr (regular cut)		\$58.00
UC-D1/2	Burr (regular cut)	NA	
TN-D1/2	Burr (regular cut)		\$58.00
UC-D1/2 LH	Burr (regular cut, left hand)	\$58.00	
TN-D1/2 LH	Burr (regular cut, left hand)		\$68.00
UC-E1/2	Burr (regular cut)	NA	
TN-E1/2	Burr (regular cut)		\$58.00
UC-F1/2	Burr (regular cut)	\$48.00	
TN-F1/2	Burr (regular cut)		\$58.00

Lasts **THREE** times longer.



UC-84-T/SP TN-84-T/SP UC-88-A/SP TN-88-A/SP UC-A3/8 SP TN-A3/8 SP UC-A1/2 SP TN-A1/2 SP



UC-A1/2 TN-A1/2 UC-A1/2 LH TN-A1/2 LH left hand UC-B1/2 TN-B1/2 UC-B1/2 DIA TN-B1/2 DIA UC-C1/2 TN-C1/2 UC-D1/2 TN-D1/2 UC-D1/2 LH TN-D1/2 LH left hand UC-E1/2 TN-E1/2 UC-F1/2 TN-F1/2

Diamond Cut

BLUE MOUNTED STONES



Blue are made of compressed Aluminum Oxide. Non-contaminating. Perfect for semi and precious metals.

MS401	Blue Mounted Stone	\$15.00/doz
MS403	Blue Mounted Stone	\$15.00/doz
MS404	Blue Mounted Stone	\$15.00/doz
MS405	Blue Mounted Stone	\$15.00/doz



MS406	Blue Mounted Stone	\$15.00/doz
MS407	Blue Mounted Stone	NA
MS408	Blue Mounted Stone	\$15.00/doz
MS409	Blue Mounted Stone	\$15.00/doz
MS410	Blue Mounted Stone	\$15.00/doz

GREEN MOUNTED STONES



Green carborundum stones are ideal for porcelain finishing, shaping and adjusting. They are neither too hard nor too soft, which makes cutting easy. To prevent contamination of dental alloys, we recommend labs to avoid using Green stones on alloys.

MS412	Green Mounted Stone	\$15.00/doz
MS413	Green Mounted Stone	\$15.00/doz
MS414	Green Mounted Stone	\$15.00/doz
MS415	Green Mounted Stone	\$15.00/doz
MS416	Green Mounted Stone	\$15.00/doz



MS417	Green Mounted Stone	NA
MS418	Green Mounted Stone	\$15.00/doz
MS419	Green Mounted Stone	NA
MS420	Green Mounted Stone	\$15.00/doz
MS421	Green Mounted Stone	\$15.00/doz
MS422	Green Mounted Stone	\$15.00/doz

WHITE MOUNTED STONES

White are made of compressed aluminum Oxide. For Nickel-Chrome Cobalt, precious and semi-precious alloys. Non-contaminating - fine grain.

MS430	White Mounted Stone	\$15.00/doz
MS431	White Mounted Stone	\$15.00/doz
MS432	White Mounted Stone	\$15.00/doz
MS433	White Mounted Stone	\$15.00/doz
MS434	White Mounted Stone	\$15.00/doz
MS435	White Mounted Stone	NA



PINK MOUNTED STONES

Pink are also made of compressed aluminium Oxide. Non-Contaminating. Perfect for semi - precious Metal.

MS424	Pink Mounted Stone	\$15.00/doz
MS425	Pink Mounted Stone	\$15.00/doz
MS426	Pink Mounted Stone	\$15.00/doz
MS427	Pink Mounted Stone	\$15.00/doz
MS428	Pink Mounted Stone	NA
MS429	Pink Mounted Stone	\$15.00/doz



BROWN MOUNTED STONES

Harder than Blue. For partial dentures chrome-cobalt, non-precious alloys, non-contaminating - fine grain.

MS436	Brown Mounted Stone	NA
MS437	Brown Mounted Stone	\$15.00/doz
MS438	Brown Mounted Stone	\$15.00/doz
MS439	Brown Mounted Stone	\$15.00/doz
MS440	Brown Mounted Stone	NA
MS441	Brown Mounted Stone	NA



Our Mounted Stones are available in 5 different composites (colors) and at least 6 different shapes.

Blue	Perfect for semi and precious metals
Green	Ideal for porcelain finishing, shaping and adjusting
White	For Nickel-Chrome cobalt, precious and semi-precious alloys
Pink	For semi and precious metals
Brown	For partial dentures Chrome-Cobalt, non-precious alloys, non-contaminating - fine grain

ARBOR BANDS



Q117 Mandrel for 1/4"

Q119 Mandrel for 3/8"

Q122 RH Mandrel for 1/2"
Q120 LH Mandrel for 1/2"

Q126 RH Mandrel for 3/4"
Q124 LH Mandrel for 3/4"

ARBOR BAND SANDPAPER

Available in four diameters:
Fine 120 Grit, Medium 80 Grit & Course 60 Grit

	AB280 For 1/4" Mandrel, Fine	\$13.50/100
	AB310 For 1/4" Mandrel, Medium	\$13.50/100
	AB340 For 1/4" Mandrel, Coarse	\$13.50/100
	AB190 For 3/8" Mandrel, Fine	\$13.50/100
	AB220 For 3/8" Mandrel, Medium	\$13.50/100
	AB250 For 3/8" Mandrel, Coarse	\$13.50/100
	AB100 For 1/2" Mandrel, Fine	\$13.50/100
	AB130 For 1/2" Mandrel, Medium	\$13.50/100
	AB160 For 1/2" Mandrel, Coarse	\$13.50/100
	AB010 For 3/4" Mandrel, Fine	\$13.50/100
	AB040 For 3/4" Mandrel, Medium	\$13.50/100
	AB070 For 3/4" Mandrel, Coarse	\$13.50/100

BRUSHES

Available in soft, standard stiff, and extra stiff bristles

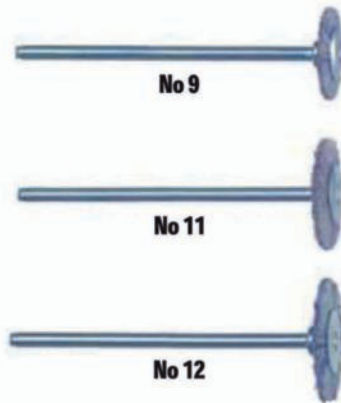

No 9

No 11

No 12

ARB011	No 9 = 5/8" dia Soft	\$14.00/doz
ARB041	No 9 = 5/8" dia Std. Stiff	\$14.00/doz
ARB071	No 9 = 5/8" dia Extra Stiff	\$14.00/doz
ARB021	No 11 = 3/4" dia Soft	\$14.00/doz
ARB051	No 11 = 3/4" dia Std. Stiff	\$14.00/doz
ARB081	No 11 = 3/4" dia Extra Stiff	\$14.00/doz
ARB031	No 12 = 13/16" dia Soft	\$14.00/doz
ARB061	No 12 = 13/16" dia Std. Stiff	\$14.00/doz
ARB091	No 12 = 13/16" dia Extra Stiff	\$14.00/doz

CLASP POLISHERS - 15/16" X 1/4" (23.8 x 6.3mm)

CP010	Reg. Grey	\$20.00/100	
CP020	Dark Grey	\$20.00/100	
CP050	Black	\$20.00/100	
CP070	Blue	\$20.00/100	
CP080	Red	\$20.00/100	

MANDRELS



HSM041
Corkscrew 3/32" Shank
\$11.00/doz





HSM081
Spiral w/Hex Nut 3/32" Shank
\$11.00/doz

CONSUMABLES

MOUNTED RUBBER POINTS

Long lasting, premium mounted rubber, provides superior polishing.

\$14.00/doz

tip color	compound type	type of use					
red	aluminum oxide	coarse	MR201	MR202	MR203	MR204	MR205
white	aluminum oxide	ultra fine	MR211	MR212	MR213	MR214	MR215
blue	silicon carbide	final polishing of all metals	MR221	MR222	MR223	MR224	MR225
green	silicon carbide	for amalgam and gold	MR231	MR232	MR233	MR234	MR235
black	silicon carbide	coarsest for amalgam and gold	MR241	MR242	MR243	MR244	MR245
brown	aluminum oxide	for refinishing all metals	MR251	MR252	MR253	MR254	MR255
gray	silicon carbide	for touch-up polishing	MR261	MR262	MR263	MR264	MR265



RUBBER WHEELS

Three aluminum oxide to choose from
Three Silicon carbides to choose from

\$29.00/100

wheel color	compound type	degree of coarseness or fineness	7/8"		5/8"	
			flat edge	knife edge	flat edge	knife edge
red	aluminum oxide	fine	RWK701	RWK703	RWF700	RWK702
white	aluminum oxide	extra fine	RWK721	RWK724	RWF721	RWK723
blue	silicon carbide	medium fine	RWK731	RWK731	RWF728	RWK730
green	silicon carbide	coarse	RWK751	RWK752	RWF749	RWK753
black	silicon carbide	extra coarse	RWK759	RWK759	RWF756	RWK758
brown	aluminum oxide	coarse	RWK766	RWK766	RWF763	RWK765



MIZZY HEATLESS WHEELS



1/16"					
	GHW240	GHW210	GHW180	GHW150	GHW120
1/8"					
	GHW230	GHW200	GHW170	GHW140	GHW110
3/16"					
	GHW220	GHW190	GHW160	GHW130	GHW100
	MIZZY-USA HEATLESS	MIZZY-USA HEATLESS	MIZZY-USA HEATLESS	MIZZY-USA HEATLESS	MIZZY-USA HEATLESS

Heatless Original Wheels (grey) are made of a silicone carbide abrasive to make a unique, non-loading binder for rapid reduction through the final shaping of non-precious, semi-precious, precious alloys, porcelain, acrylic, denture teeth and natural dentition, without generating excessive heat. These wheels come in 15 different sizes and in regular grit. They also withstand a maximum of 20,000 rpm.

\$32.00/50

MIZZY WHITE HEATLESS WHEELS



1/16"					
	WHW243	WHW246	WHW249	WHW253	WHW256
1/8"					
	WHW242	WHW245	WHW248	WHW252	WHW255
3/16"					
	WHW241	WHW244	WHW247	WHW251	WHW254
	MIZZY-USA HEATLESS	MIZZY-USA HEATLESS	MIZZY-USA HEATLESS	MIZZY-USA HEATLESS	MIZZY-USA HEATLESS

White Heatless Wheels are non-contaminating, aluminum oxide wheels that can be used on either porcelain or precious and semi-precious metal. They cut fast, run true, wear evenly, and won't ever clog. They also come in 15 different sizes.

\$31.00/50

CONSUMABLES

JOE DANDY TYPE SEPARATING DISCS

Available in double cutting for end cutting and safe-sided for finishing and in both flat and cup shaped.

\$19.00/100

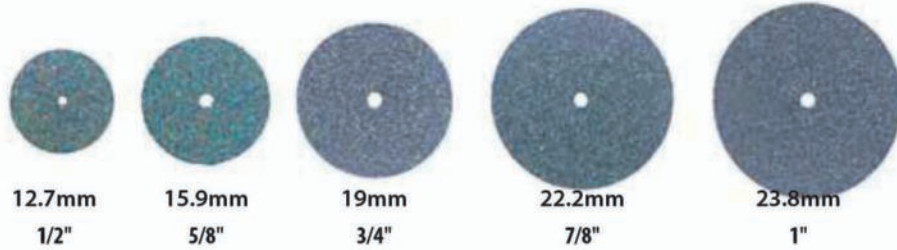

Flat Double Cutting	JD180	JD190	JD200	JD210	JD220
Flat Safe-Sided	JD230	DJ240	JD250	JD260	JD270
Cup Double Cutting	JD280	JD290	JD300	JD310	JD320
Cup Outside Cutting	JD330	JD340	JD350	JD360	JD370
Cup Inside Cutting	JD380	JD390	JD400	JD410	JD420

MIZZY FLEXIS

Diamond grinding discs - flexible and versatile.
(1 mandrel and 8 discs included.)

\$44.00/8

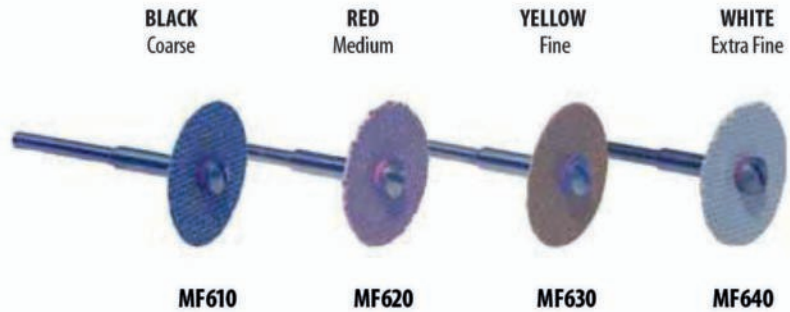

ALUMINUM OXIDE ROUGHING DISCS

Pure aluminum oxide disc, non-contaminating, long-lasting, very fast cutting, and odorless.



RD620
35mm x 1.7mm
\$36.50/100



RD621
32mm x 2.2mm
\$36.50/100



RD622
22mm x 3.5mm
\$36.50/100

KEYSTONE CUT-OFF WHEELS

These Cut-Off Wheels are strong and durable. Made with pure aluminum oxide provide non-contaminating fast free cutting of all metals. The wheels come in a reddish-brown color and have a max of 25,000 rpm.



CW320
1 1/4" x .062"
31.8 x 1.6mm
\$25.00/100



CW310
1 1/2" x .040"
38.8 x 1.1mm
\$25.00/100



CW300
1 1/2" x .025"
38.8 x .63mm
\$25.00/100

SEPARATING DISCS



SD650
7/8" x .009"
22mm x 0.2mm
\$46.25/100



SD651
7/8" x .006"
22mm x 0.15mm
\$46.25/100

HIGH SPEED MANDRELS



HSM051 H.P., High-Speed reinforced 3/32" shank \$14.00/doz



HSM090 H.P., 3/32" shank, 1/16" screw \$15.00/doz



HSM056 Mandrel tapered handpiece \$23.00/doz



Q154 Mandrel (right hand)
1/4" shank-stainless steel \$13.00 each



Q152 Mandrel (left hand)
1/4" shank-stainless steel \$13.00 each

MUSLIN BUFFS

Our Muslin Buffs are made of carefully selected material, each ply is full cut. Stitching is uniform and will not pull out.

MB120	2" x 30 ply Muslin Buffs	\$24.00/doz
MB130	3" x 24 ply Muslin Buffs	\$18.00/doz
MB135	3" x 30 ply Muslin Buffs	\$23.00/doz
MB140	3" x 35 ply Muslin Buffs	\$24.00/doz
MB150	4" x 24 ply Muslin Buffs	\$30.00/doz
MB160	4" x 30 ply Muslin Buffs	\$33.00/doz
MB170	4" x 42 ply Muslin Buffs	\$37.00/doz
MB180	5" x 30 ply Muslin Buffs	\$40.00/doz
MB190	5" x 45 ply Muslin Buffs	\$58.00/doz
MB200	6" x 30 ply Muslin Buffs	\$59.00/doz



Above photo is 40% of actual size

SPIRAL CHUCKS

Taper shaft spirals also available in Brass. See page 25.

R137	Spiral Taper Shaft RH • Fits standard jewelers taper	\$14.00
R136	Spiral Taper Shaft LH • Fits standard jewelers taper	\$14.00
Q134	Spiral Chuck RH	\$13.00
Q132	Spiral Chuck LH (tip painted red)	\$13.00



LATHE WHEELS



FINE (green) 120 Grit
MEDIUM (black) 46-60 Grit
COARSE (white) 36-46 Grit
 All three grits come in either 3" x 1/4" or 3" x 3/8".

The 3" x 1/4" lathe wheels (picture here) come in three different grits. All three grits come in either 3" x 1/4" or 3" x 3/8":

	BLACK 3 x 1/4 x 1/4" - (76 x 6.3mm) LW801	\$9.00
	GREEN 3 x 1/4 x 1/4" (76 x 6.3mm) LW802	\$9.00
	WHITE 3 x 1/4 x 1/4 (76 x 6.3mm) LW803	\$9.00

The 3" x 3/8" lathe wheels are not pictured, however they are identical to the 3" x 1/4" lathe wheels except for the edge thickness.

	BLACK 3 x 3/8 x 1/4" (76 x 9.5mm) LW804	\$10.00
	GREEN 3 x 3/8 x 1/4" (76 x 9.5mm) LW805	\$10.00
	WHITE 3 x 3/8 x 1/4" (76 x 9.5mm) LW806	\$10.00

See pages 21 & 25 for stone chucks.

MODEL TRIMMER WHEELS

Model Trimmer Wheels for Ray Foster model trimmers as well as other brands.

- 10" Diameter
- 1" Hole
- 5/8" Drive Hole



C16TB	Model Trimmer Wheel (Coarse)	\$29.00 each
C20TB	Model Trimmer Wheel (Medium Coarse)	\$29.00 each
C30TB	Model Trimmer Wheel (Fine)	\$29.00 each
C60TB	Model Trimmer Wheel (Extra Fine)	\$29.00 each

ECONO CUTTERS

See pages 21 & 25 for thin econo cutter stone chucks.

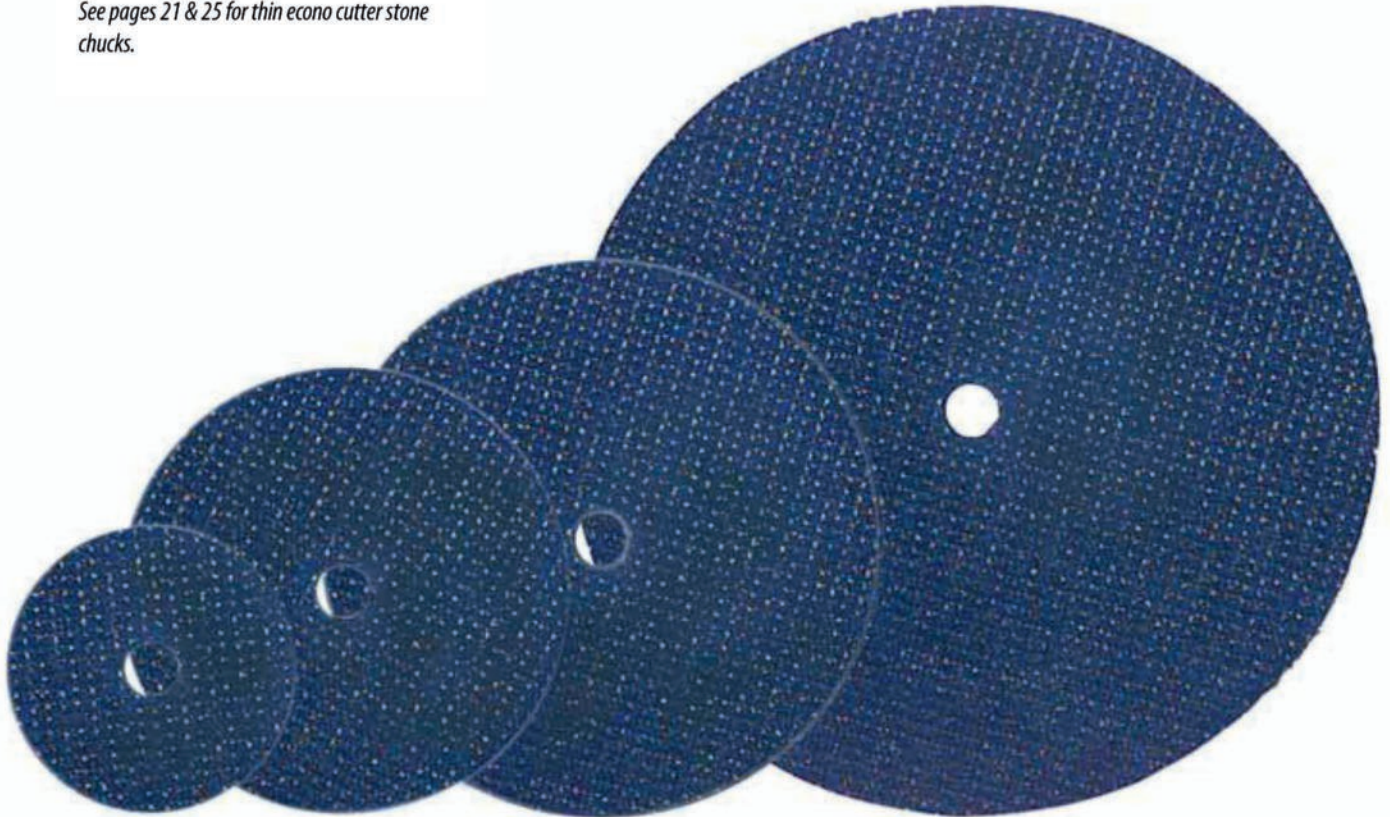

EC675	EC676	EC677	EC678
1 1/2" x 1/32 x 1/4"	2 1/2" x 1/32 x 1/4"	3" x 1/32 x 1/4"	4" x 1/32 x 1/4"
\$29.00/12	\$18.00/6	\$19.00/6	\$32.00/6

FACTORY REPAIR

Our service department assures prompt repairs of all Wells products. We have a one to two day turn around time which will get you back into production quickly. There is no return authorization necessary.

When we receive your equipment for repair it is thoroughly checked for worn or damaged parts. Wells equipment can always be rebuilt to factory specifications with a fully reinstated prorated warranty. Your equipment will come back to you just like new at a significant savings over buying new equipment.

BEFORE YOU SEND YOUR EQUIPMENT FOR REPAIR:

1. Consult the technical bulletin or user's manual that came with your equipment. Problems are often solved by simple maintenance procedures. All technical bulletins and user's manuals can be found on our web site www.wellsdental.com. Simply click on "documents" and click on the appropriate manual.
2. Call our toll-free number 1-800-233-0521 and ask for technical support. Our experience may save you extra work and delay.
3. If the equipment needs service beyond your means, ship it directly to us and we will be happy to repair and return it. No return authorization is necessary. We encourage you to send Wells equipment directly to us.
4. UPS is the only delivery company that comes to our location daily. USPS is another alternative. Other major carriers do not deliver to our rural location. To avoid delays please ship UPS to our street address. If you prefer to use the postal service please mail to our post office box.
5. Ship only Wells products to us with your name, your company name, UPS deliverable shipping address (no P.O. boxes) and phone number along with a brief description of the problem and any special instructions. In order to keep our turn around repair service quick we will not call you with an estimate unless you specifically ask in writing. Maximum repair prices are well under the cost of new equipment. Estimates will take an additional one to two days. If you do not have an account with us, your items will be shipped back to you UPS ground COD. If you would like to avoid COD charges, we encourage you to include in your note your credit card number and expiration date.

EQUIPMENT EXCHANGE

If you cannot be without your equipment for the one or two days it takes us to repair your item our exchange service is available. We can send you a rebuilt item with the understanding that you will return your old item to us. Enclosed with the packing list on top of the box you will find a UPS prepaid RS (return service) label. Simply enclose your old equipment in the same box and affix the prepaid return label. You can give the package to any UPS driver and the package will be returned to us. The equipment exchanged will be invoiced at full retail price which serves as a deposit. Upon receipt of your old item, appropriate credit will be issued for the difference between the retail price and the exchange price. No credit will be issued for exchanges not returned within 30 days of invoice date.

TRADE-IN

We offer a trade-in service for equipment from other manufacturers. If you would like to update to a Wells High Speed Spindle, a Wells Super Quick Chuck or a Wells Handpiece and/or Arm we offer a discount on new equipment.



WELLS

DENTAL, INC.

Presort
Standard
U.S. Postage
PAID
Salt Lake City, UT
Permit #354

5860 FLYNN CREEK RD
PO BOX 106
COMPTCHE, CA 95427-0106
USA



TOLL FREE WITHIN U.S.

VOICE 1.800.233.0521

FAX 1.800.809.7553

OUTSIDE U.S.

VOICE 707.937.0521

FAX 707.937.2809

WEB SITE

www.wellsdental.com

BUSINESS HOURS

MON-FRI 8 AM - 4:30 PM
PACIFIC TIME

