

### INSTALLATION OF SEMICONDUCTOR KIT PRODUCT NUMBER F208

#### 1.0 OVERVIEW

The F208 SEMICONDUCTOR KIT is for replacement of the semiconductor circuit in the WELLS FOOT CONTROL, product numbers F011 and F015.

#### 2.0 TOOLS & MATERIALS REQUIRED

F208 SEMICONDUCTOR KIT, straight blade screwdrivers (1/4", 3/16" and 1/8"), 7/16" **THIN WALL** socket wrench, 9/16" open end wrench, soldering gun, rosin core solder and needle nose pliers.

#### 3.0 DISASSEMBLY

- 3.1 Disconnect the Engine Unit main power cord from the receptacle.
- 3.2 Disconnect the five wire cord from the foot control.
- 3.3 Remove the four rubber feet and lift off the base cover.
- 3.4 Fold back the paper insulation cover.
- 3.5 Remove the flat head and the round head screws that hold the curved phenolic arm (1). See Figure 1. Remove the phenolic arm.
- 3.6 Disconnect the white wire from the reversing switch.
- 3.7 Disconnect the white wire that connects the triac to the fuse holder. (If the foot control does not have a fuse, unsolder the white wire at the terminal on the six prong plug.)

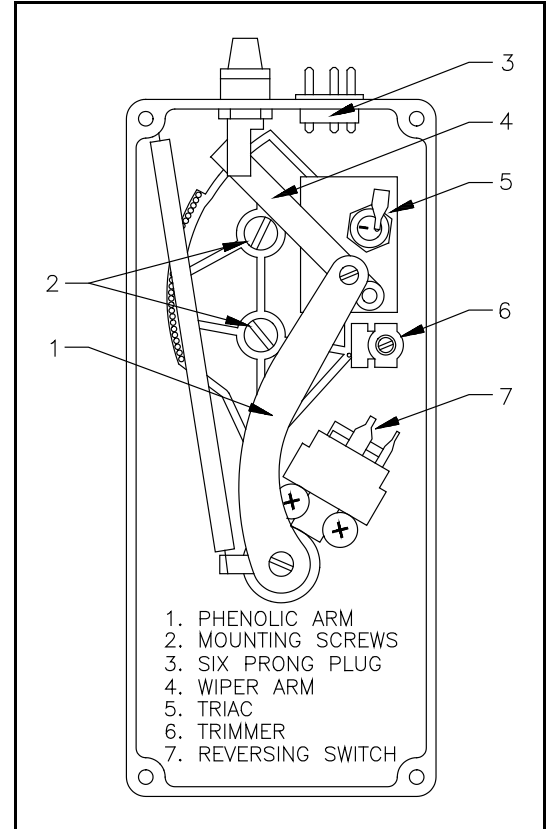

Figure 1. Components

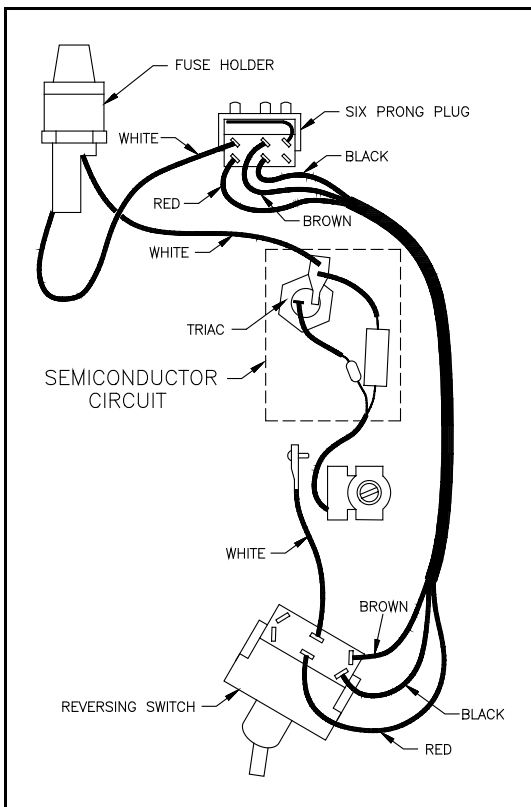

Figure 2. Wiring diagram

- 3.8 Remove the two mounting screws (2 in Figure 1.) that hold the plastic circuit board and remove the circuit board.
- 3.9 Unsolder the black insulated wire that is connected to the trimmer. Note that there is a small blue wire connected to the same terminal.
- 3.10 Note the position of the semiconductor circuit before its removal. Using the 9/16" end wrench as a backup, remove the recessed nut that holds the triac (5) with the 7/16" thin wall socket wrench.
- 3.11 Remove the semiconductor circuit. Set it aside so it will not get mixed up with the new one.

#### 4.0 INSTALLATION AND ASSEMBLY

- 4.1 Place the new semiconductor circuit into the circuit board in the same position as the old one.
- 4.2 Place the 1/4" star washer on the stud of the triac and start the nut.
- 4.3 Using the 9/16" end wrench on the triac for backup, tighten the nut with the 7/16" socket.
- 4.4 Wrap the end of the black insulated wire around the trimmer terminal making sure that the small blue wire is still connected. Solder the wires to the terminal using rosin core solder.

- 4.5 Fasten the circuit board into position with the two mounting screws. See 2 in Figure 1. The exact position of the circuit board will be adjusted later.
- 4.6 Connect the white wire that comes from the triac to the fuse holder. Make sure the white wires are connected to the fuse holder as illustrated in Figure 2. (If the foot control does not have a fuse, cut the connector from the end of the white wire. Strip the wire 3/16" and solder it to the terminal of the six prong plug. See Figure 3.
- 4.7 Connect the white wire that comes from the heat sink (brass bracket) to the correct terminal on the reversing switch. See Figure 2 or 3.
- 4.8 Install the phenolic arm. The flat head screw fastens the larger end of the phenolic arm to the post from the pedal. The small round head screw fastens the smaller end of the phenolic arm to the brass crank pin of the wiper arm.
- 4.9 Push the pedal sideways and depress it so the control is in reverse. Depress the pedal to its full extent and check if the wiper arm (4 in Figure 1.) is riding on the copper bar. Let the pedal return to a non depressed position but still in reverse. Check that the wiper arm is past the last brass contact pin. If not, reposition the circuit board by loosening the mounting screws and moving it. Tighten the mounting screws and check again. The wiper arm should rest on the copper bar when the pedal is depressed and should be past the last brass contact pin when the pedal is released.
- 4.10 Return the pedal to forward. Depress the pedal to its full extent and check if the wiper arm is riding on the copper bar. Let the pedal return to a non depressed position in forward. Check that the wiper arm is past the last brass contact pin by at least 1/4". If not, reposition the circuit board again and repeat step 4.9. The wiper arm should rest on the copper bar when the pedal is depressed in both forward and reverse and it should also be past the last brass contact pin when the pedal is released in both forward and reverse. Tighten the two mounting screws firmly.
- 4.11 A short circuit in any of the connections may cause a semiconductor failure. Be sure to check each wire from its connection along its whole length to make sure that the bare areas and terminals are separated by a gap of at least 1/16". Check all the connections at the six prong plug. Check the leads on the triac and the semiconductor circuit. Check all the connections and jumpers at the reversing switch. Check the connections at the trimmer.
- 4.12 After confirming the circuits are correct, fold down the paper insulation cover. Place the base cover so the hole allows access to the trimmer and fasten the four rubber feet.

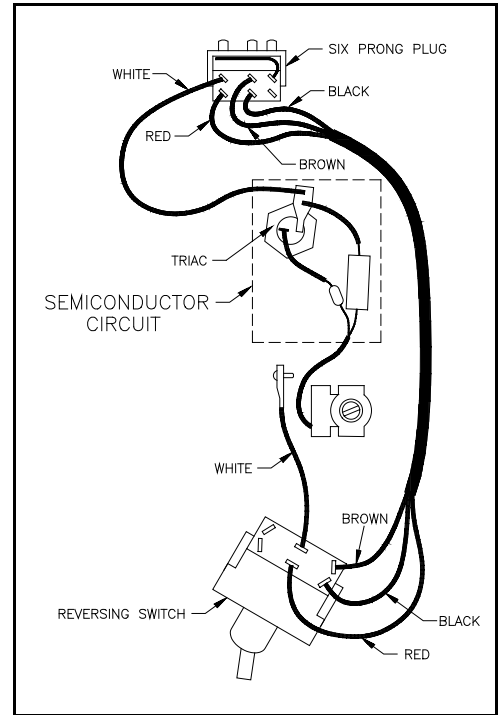
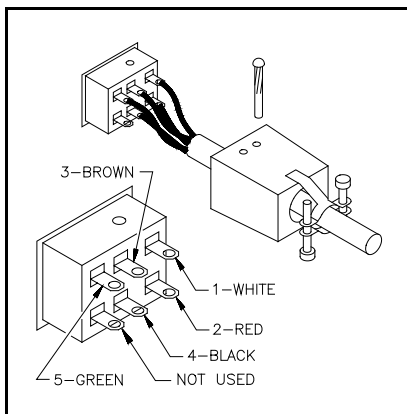

**Figure 3. Wiring diagram - no fuse**

## 5.0 WIRING CHECK

Before putting the foot control back into service, a careful check of all other wiring is necessary to prevent a recurrence of the semiconductor failure.

- 5.1 Check the five wire cord from the engine carefully. Replace the cord if cuts, crimps or abrasions are found.
- 5.2 A short in the connector at the end of the five wire cord is a prime cause for semiconductor failure. Loosen the strain relief clamp screws on the connector. See Figure 4. Push out the small pin in the connector with an awl or small diameter tool. Pull back the cover and examine the connections carefully. Make sure that the terminals are not bent and are separated by at least 1/8". Solder any loose or frayed connections and assemble the cover.
- 5.3 If the foot control has a fuse, check that it is not blown. Replace it with the same type and rating of fuse only. Order WELLS part number F109 FUSE 5 AMP PKG-2 or use a type 3AG fast acting 250 volt, 5.0 amp fuse.
- 5.4 Connect the five wire cord to the foot control. Plug the Engine Unit main power cord into a grounded receptacle.



**Figure 4. Five wire cord connector**

## 6.0 SLOW SPEED ADJUSTMENT

- 6.1 The slow speed trimmer is adjusted with a small screwdriver through the hole in the base plate. See Figure 5. Place the foot control upside down on a bench. Depress the pedal slowly until the motor just starts rotating. Hold the pedal in this position and turn the trimmer to select the desired speed.

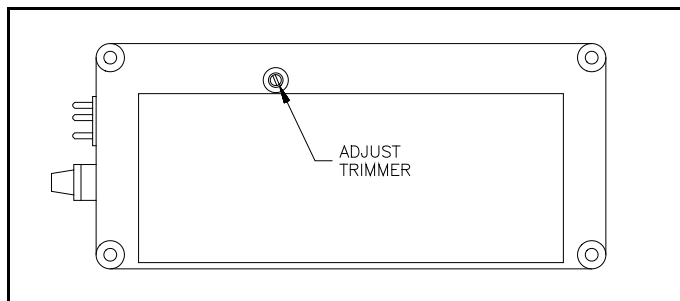

Figure 5. Bottom of Foot Control

The installation of the Semiconductor kit is now complete. If you have any questions or problems, please call WELLS DENTAL, INC. at 1-800-233-0521.